

bizhub C4050i/C3350i

Quick Guide

Safety Information	1
Before Using this Machine	9
How to Use the HTML User's Guide	11
About This Machine	12
About Panels	17
Loading the Original and Paper	21
Available Operations in this Machine	25
Registering a Destination	29
Read this if You Have a Problem	31

1 Safety Information

1.1 Introduction

This [Quick Guide] uses illustrations to describe operating procedures for the most commonly used functions in an easy-to-understand way.

Start by using this manual to become proficient with the useful functions that this machine offers.

For details on the various functions, refer to the User's Guides on the User's Guide CD included with this machine.

In order to operate the machine safely and properly, be sure to read the safety information on page 1 of this manual before use.

In addition, this manual contains the following information. Be sure to read the manual before using the machine.

- Items that must be observed to use the machine safely
- Information regarding product safety
- Precautions when using the machine

The illustrations and screens used in this manual may appear slightly different from views of the actual equipment and screens.



Tips

- Please keep this manual as well as the attached CD/DVD in a safe place where you can access them easily.

1.2 Environmental information

Environmental benefits of power management

Electricity consumption of a device depends on both its properties and the way of using the device.

Suitable power management setting offers you resource saving usage way. By setting the time to go into power saving modes (e.g. sleep mode) shorter (or optimal), electricity consumption can be reduced.

Recycled paper

This product can print on recycled paper and environmental stewardship initiatives certified paper which complies with European standard EN 12281 as well as virgin paper. In addition it can print on lighter paper, 64g/m² for example. Using such light paper contributes to resources-saving.

Duplex printing

With a product which has a duplex unit, you can print on both sides of paper automatically.

Using this function leads to reducing consumption of natural resources and your cost.

Attached printer driver provides this duplex printing function as initial setting in your computer (The setting can be changed after installation manually).

1.3 Safety information

This section contains detailed instructions on the operation and maintenance of this machine. To achieve optimum utility of this device, all operators should carefully read and follow the instructions in this manual.

Please read the following section before connecting the machine to the supply. It contains important information related to user safety and preventing equipment problems.

Make sure that you observe all of the precautions that appear in different sections of this manual.

KMI_Ver.03_E

Reference

- Some parts of the contents of this section may not correspond with the purchased product.

Warning and precaution symbols

Be sure to observe the safety precautions.

This manual contains the instructions that should be strictly observed at all times to prevent injury to yourself and other persons as well as damage to property.

Injuries and damage that might be caused by using the product improperly are classified according to the following symbols.

Pictorial indication	Description
WARNING	Improper handling can cause serious injury or death.
CAUTION	Improper handling can cause minor injury or damage to houses and property.

These are some of major exemplary graphical symbols.

Graphic symbols	Descriptions	Graphic symbols	Descriptions	Graphic symbols	Descriptions
	General prohibition		Do not disassemble		Do not touch
	General instruction		Ground/Earth		Unplug from outlet
	General precaution		High temperature		Electrical shock hazard

<Power source connection>

WARNING

Do not use any power cord other than the one supplied in the package or attached on the products. If a power cord is not supplied, use only the power cord and plug that are specified in the user documentation. Failure to use this cord could result in a fire or electrical shock. If the power cord supplied in the package cannot be used in the country where this product was sold, use a power cord that meets the following conditions or contact your Technical Representative.

- The power cord has voltage and current rating appropriate for the rating plate on this machine.
- The power cord meets regulatory requirements for the area.
- The power cord is provided with grounding pin/terminal.

Do not use the power cord to other products. Failure to do that could result in a fire or electrical shock.

Do not scratch, abrade, place a heavy object on, heat, twist, bend, step on, pull on, or damage the power cord. Use of a damaged power cord (exposed core wire, broken wire, etc.) could result in a fire or breakdown. Should any of these conditions be found, immediately turn OFF the power switch, unplug the power cord from the power outlet, and then call your authorized service representative.

WARNING

Do not use the power source voltage other than being specified on the machine. Failure to do that could result in a fire or electrical shock.	
Do not use a multiple outlet adapter to connect any other appliances or machines. Use of a power outlet for more than the marked current value could result in a fire or electrical shock.	
Do not use an extension cord. Use of an extension cord could cause a fire or electric shock. If the power cord furnished with the product is not long enough to be plugged into a wall outlet, contact your Technical Representative.	
Do not unplug and plug in the power cord with a wet hand, as an electrical shock could result.	
Plug the power cord all the way into the power outlet. Failure to do this could result in a fire or electrical shock.	
Make sure to ground this product. (Connect the power cord to an electrical outlet that is equipped with a grounding terminal.) Failure to do so and an unlikely event of leakage could result in a fire or electrical shock.	

CAUTION

The outlet must be near the equipment and easily accessible. Otherwise you can not pull out the power plug when an emergency occurs.	
Do not place any objects around the power plug, as the power plug may be difficult to pull out when an emergency occurs.	
Do not tug the power cord when unplugging. Pulling on the power cord could damage the cord, resulting in a fire or electrical shock.	
Remove the power plug from the outlet more than one time a year and clean the area between the plug terminals. Dust that accumulates between the plug terminals may cause a fire.	

<Installation>

WARNING

Keep this bag away from babies and children. Do not use in cribs, beds, carriages, or playpens. The thin film may cling to nose and mouth and prevent breathing. This bag is not a toy.	
Do not place a flower vase or other container that contains water, or metal clips or other small metallic objects on this product. Spilled water or metallic objects dropped inside the product could result in a fire, electrical shock, or breakdown. Should a piece of metal, water, or any other similar foreign matter get inside the product, immediately turn OFF the power switch, unplug the power cord from the power outlet, and then call your Technical Representative or your authorized service representative.	
Make sure that the power cord is placed on a site in which no person would step on or trip over it. Stepping on or tripping over the power cord could heat the power cord, resulting in a fire or electric shock.	

CAUTION







<If instructed to use fixing legs> When the product has been installed, fix the product using the fixing legs. Not using the fixing legs could cause the product to move or topple over.	
Do not place the product in a dusty place, or a site exposed to soot or steam, near a kitchen table, bath, or a humidifier. A fire, electrical shock, or breakdown could result.	
Do not place this product on an unstable or tilted bench, or in a location subject to a lot of vibration and shock. It could drop or fall, causing personal injury or mechanical breakdown.	
Do not let any object plug the ventilation holes of this product. Heat could accumulate inside the product, resulting in a fire or malfunction.	
Whenever moving this product, be sure to disconnect the power cord and other cables. Failure to do this could damage the cord or cable, resulting in a fire, electrical shock, or breakdown.	
When moving this product, always hold it at the locations specified in the User's Guide or other documents. If the unit is moved while held at locations other than those specified, it may fall, causing severe personal injury.	

<Using the product>

WARNING

Do not modify this product, as a fire, electrical shock, or breakdown could result. If the product employs a laser, the laser beam source could cause blindness.	
Do not attempt to remove the covers and panels which have been fixed to the product. Some products have a high-voltage part or a laser beam source inside that could cause an electrical shock or blindness.	
Do not keep using this product, if this product becomes inordinately hot or emits smoke, or unusual odor or noise. Immediately turn OFF the power switch, unplug the power cord from the power outlet, and then call your Technical Representative or your authorized service representative. If you keep on using it as is, a fire or electrical shock could result.	
Do not keep using this product, if this product has been dropped or its cover damaged. Immediately turn OFF the power switch, unplug the power cord from the power outlet, and then call your Technical Representative or your authorized service representative. If you keep on using it as is, a fire or electrical shock could result.	
Do not use flammable sprays, liquids, or gases inside or near this machine. Do not clean the inside of this machine using a flammable gas duster. A fire or explosion could result.	
<If an RFID module (limited only to 13.56 MHz) for use in inside-the-machine proximity communication or electromagnetic induction heating (IH) technology (limited only to 20.05 kHz to 100 kHz) is being used> This machine generates a weak magnetic field. If you experience any unusual symptoms with your implantable medical equipment (cardiac pacemaker, etc.) while near the machine, move away from the machine and see a doctor immediately. Please call your Technical Representative or your authorized service representative if you do not understand the purchased product corresponds or not.	
<If a non-contact IC card reader is being used> If you use an implantable medical equipment (cardiac pacemaker, etc.), do not bring the IC card reader close from the implant within 12 cm at all times. The radio waves may affect implantable medical equipment (cardiac pacemaker, etc.) operations.	

CAUTION













Using this product in a poorly ventilated room for a long time or producing a large volume of copies or prints may cause the odor of exhaust air from the machine. Ventilate the room well.	
The inside of this product has areas subject to high temperature, which may cause burns. When checking the inside of the unit for malfunctions such as a paper misfeed, do not touch the locations (around the fusing unit, etc.) which are indicated by a "Caution HOT" caution label. A burn could result.	 
Unplug the product when you will not use the product for long periods of time.	
When using the machine, do not look at the light of the lamp for a prolonged time. Eyestrain could result.	
Do not use stapled paper, conductive paper (such as silver paper or carbon paper) or treated heat-sensitive/inkjet paper, otherwise a fire may result.	

<Consumables>

WARNING

Do not throw toner or a container that contains toner (e.g., toner cartridge, developing unit and Waste Toner Box) into an open flame. The hot toner may scatter and cause burns or other damage.	
---	---

CAUTION

Do not leave toner-related parts (e.g., toner cartridge, developing unit and Waste Toner Box) within easy reach of children. Licking any of these parts or ingesting toner could damage your health.	
Do not store toner-related parts (e.g., toner cartridge, developing unit and Waste Toner Box) near devices susceptible to magnetism, such as precision equipment and data storage devices, otherwise they may malfunction. They could cause these products to malfunction.	
Do not force open the toner-related parts (e.g., toner cartridge, developing unit and Waste Toner Box). If toner tumbles from the toner bottle, take utmost care to avoid inhaling it or even getting skin contact.	
If toner lands on your skin or clothing, wash thoroughly with soap and water.	
If you inhale toner, move to a place with fresh air and gargle with a lot of water repeatedly. Should you get symptoms such as coughing, seek medical advice.	
If you get toner into your eyes, immediately rinse them with running water for over 15 minutes. Seek medical advice if irritation persists.	
If you swallow toner, rinse out your mouth and drink a few glasses of water. Seek medical advice if necessary.	
Never touch the electrical contacts of the units (e.g., toner cartridge and developing unit), as an electrostatic discharge may damage the product.	
Before handling, see the user documentation for the safety information.	
<If instructed to replace the fusing unit> The fusing section is extremely hot. Before replacing the fusing unit, be sure to open doors and covers of the machine. Then, leave the machine to stand idle for a specified period of time and make sure that the fusing section has cooled down to room temperature. Failure to follow these instructions could result in a burn.	  

1.4 Regulation notices

About certified model name

This product is certified by the following model name:
KONICA MINOLTA branded model bizhub C4050i and bizhub C3350i.

CE Marking (Declaration of Conformity) for users of the European Union (EU)

Hereby, Konica Minolta declares that the radio equipment models specified above are in compliance with Directive 2014/53/EU.

The full text of the EU declaration of conformity is available at the following internet address:

"<https://www.konicaminolta.eu/en/business-solutions/support/download-center.html>".

Choose your product and open the section "Safety Documents".

Maximum radio-frequency power transmitted in the frequency band (EIRP):

Module Name, Option	Frequency Band	Radiation. Power
UK-221 includes approved Wireless module, MODEL WN4521L:	2.4 GHz	Max. 20 dBm
	5 GHz	Max. 23 dBm
EK-P09 includes approved Wireless module, MODEL MBH7BLZ02:	2.4 GHz	Max. 3 dBm

Note: 5 GHz may not be available

This radio equipment is restricted to indoor use only. Outdoor use is prohibited.

This restriction applies to all the countries listed in the table below.



AT	BE	BG	CH	CY	CZ	DE	DK	EE
EL	ES	FI	FR	HR	HU	IE	IS	IT
LI	LT	LU	LV	MT	NL	NO	PL	PT
RO	SE	SI	SK	TR	UK			

For Brasilia users/ Para usuários de Brasília

The UK-221 (includes wireless module, model WN4521L) are not provided for the Brazilian market./ O UK-221 (inclui módulo sem fio, modelo WN4521L) não é fornecido para o mercado brasileiro.

USER INSTRUCTIONS FCC PART 15 - RADIO FREQUENCY DEVICES (for U.S.A. users)

FCC: Declaration of Conformity
Product Type Multi Function Printer
Product Name bizhub C4050i, bizhub C3350i

This device complies with Part 15 of the FCC Rules
Operation is subject to the following two conditions:
(1) This device may not cause harmful interference, and
(2) this device must accept any interference received, including interference that may cause undesired operation.

Konica Minolta Business Solutions U.S.A., Inc.
100 Williams Drive
Ramsey, NJ 07446
201-825-4000

<https://kmbs.konicaminolta.us>

NOTE:

This equipment has been tested and found to comply with the limits for a Class B digital device, pursuant to Part 15 of the FCC Rules. These limits are designed to provide reasonable protection against harmful interference in a residential installation. This equipment generates, uses and can radiate radio frequency energy and, if not installed and used in accordance with the instructions, may cause harmful interference to radio communications. However, there is no guarantee that interference will not occur in a particular installation. If this equipment does cause harmful interference to radio or television reception, which can be determined by turning the equipment off and on, the user is encouraged to try to correct the interference by one or more of the following measures:

- Reorient or relocate the receiving antenna.
- Increase the separation between the equipment and receiver.
- Connect the equipment into an outlet on a circuit different from that to which the receiver is connected.
- Consult the dealer or an experienced radio/TV technician for help.

⚠ WARNING

- The design and production of this unit conform to FCC regulations, and any changes or modifications must be registered with the FCC and are subject to FCC control. Any changes made by the purchaser or user without first contacting the manufacturer will be subject to penalty under FCC regulations.
- This device must be used with a shielded interface cable. The use of non-shielded cables is likely to result in interference with radio communications and is prohibited under FCC rules.

INTERFERENCE-CAUSING EQUIP- MENT STANDARD (ICES-003 ISSUE 6) (for Canada users)

This Class B digital apparatus complies with Canadian ICES-003.

Cet appareil numérique de la classe B est conforme à la norme NMB-003 du Canada.

This device must be used with a shielded interface cable.

The use of non-shielded cables is likely to result in interference with radio communications and is prohibited under ICES-003.

GS Certification

This device is not intended for use in the direct field of view at visual display workplaces. To avoid incommoding reflexions at visual display workplaces this device must not be placed in the direct field of view.

Das Gerät ist nicht für die Benutzung im unmittelbaren Gesichtsfeld am Bildschirmarbeitsplatz vorgesehen. Um störende Reflexionen am Bildschirmarbeitsplatz zu vermeiden, darf dieses Produkt nicht im unmittelbaren Gesichtsfeld platziert werden.

Electromagnetic Interference

This product must be used with a shielded interface cable.

The use of non-shield cables is likely to result in interference with radio communications and is prohibited under CISPR and local rules.

Laser safety

This is a digital machine which operates using a laser. There is no possibility of danger from the laser provided the machine is operated according to the instructions in the manuals.

Since radiation emitted by the laser is completely confined within protective housing, the laser beam cannot escape from the machine during any phase of user operation.

This machine is certified as a Class 1 laser product per IEC 60825-1: 2014. This means the machine does not produce hazardous laser radiation.

Internal laser radiation

Maximum Average Radiation Power: 10.1 μ W (bizhub C4050i), 8.3 μ W (bizhub C3350i) at the laser aperture of the print head unit.

Wavelength: 770-800 nm

This product employs a Class 3B laser diode that emits an invisible laser beam.

The laser diode and the scanning polygon mirror are incorporated in the print head unit.

The print head unit is NOT A FIELD SERVICE ITEM:

Therefore, the print head unit should not be opened under any circumstances.

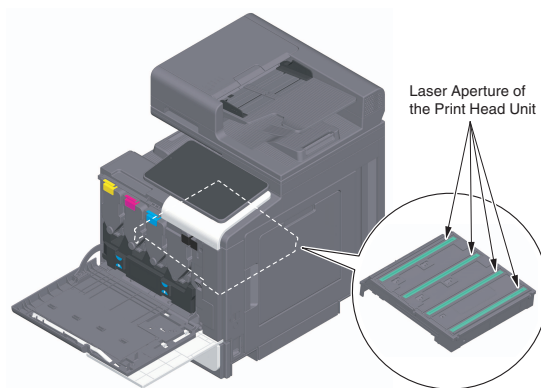

CDRH regulations

This machine is certified as a Class 1 Laser product under Radiation Performance Standard according to the Food, Drug and Cosmetic Act of 1990. Compliance is mandatory for Laser products marketed in the United States and is reported to the Center for Devices and Radiological Health (CDRH) of the U.S. Food and Drug Administration of the U.S. Department of Health and Human Services (DHHS). This means that the device does not produce hazardous laser radiation.

The label shown on page 5 indicates compliance with the CDRH regulations and must be attached to laser products marketed in the United States.

⚠ WARNING

Use of controls, adjustments or performance of procedures other than those specified in this manual may result in hazardous radiation exposure.

- This is a semiconductor laser. The maximum power of the laser diode is 25 mW and the wavelength is 770-800 nm.

For European users

⚠ WARNING

Use of controls, adjustments or performance of procedures other than those specified in this manual may result in hazardous radiation exposure.

- This is a semiconductor laser. The maximum power of the laser diode is 25 mW and the wavelength is 770-800 nm.

Laser safety label

A laser safety label is attached to the outside of the machine, as shown below.

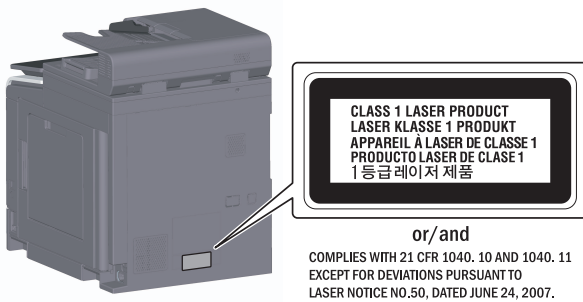

Ozone release

Locate the Machine in a Well-Ventilated Room

A negligible amount of ozone is generated during normal operation of this machine. An unpleasant odor may, however, be created in poorly ventilated rooms during extensive machine operations. For a comfortable, healthy and safe operating environment, it is recommended that the room be well ventilated.

Placer l'appareil dans une pièce largement ventilée

Une quantité d'ozone négligeable est dégagée pendant le fonctionnement de l'appareil quand celui-ci est utilisé normalement. Cependant, une odeur désagréable peut être ressentie dans les pièces dont l'aération est insuffisante et lorsque une utilisation prolongée de l'appareil est effectuée. Pour avoir la certitude de travailler dans un environnement réunissant des conditions de confort, santé et de sécurité, il est préférable de bien aérer la pièce où se trouve l'appareil.

Acoustic noise (for German users only)

Der höchste Schalldruckpegel beträgt 70 dB(A) oder weniger gemäß EN ISO 7779.

Notification for California customers

This product uses a CR Lithium Battery which contains perchlorate material.

This perchlorate warning applies to perchlorate-containing lithium batteries sold or distributed in California, USA.

"Perchlorate Material - Special handling may apply, See www.dtsc.ca.gov/hazardouswaste/perchlorate."

Recycling batteries (for Taiwan users only)

根據地方規定處理使用的電池。



This symbol means: Do not dispose of this product together with your household waste!

Please refer to the information of your local community or contact our dealers regarding the proper handling of end-of-life electric and electronic equipments. Recycling of this product will help to conserve natural resources and prevent potential negative consequences for the environment and human health caused by inappropriate waste handling.

For EU member states only

This product complies with RoHS (2011/65/EU) Directive.

USB host

Connect USB devices (Memory, Authentication, Hub etc.) devices directly to the USB host. If an extension cable is used, electromagnetic interference could occur.

Graphic symbols used on this machine

These are some of major exemplary graphical symbols.

Graphic symbols	Descriptions	Graphic symbols	Descriptions
	"ON" position		"OFF" position
	STAND-BY		push-push type switches
	Ground/Earth (Protective bonding terminal)		Ground/Earth (Protective earthing)
	CLASS II EQUIPMENT		Class II equipment with functional earthing
	Functional earthing		General precaution
	High temperature		Electrical shock hazard
	CAUTION moving fan blade		CAUTION DOUBLE POLE / NEUTRAL FUSING

1.5 Caution notations and labels

Safety precaution notations and labels appear on this machine at the following positions. Be very careful that an accident does not occur when operations such as removing paper jams and staple jams are performed.

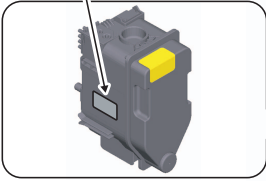



⚠ WARNING
Do not throw a container that contains toner into an open flame. The hot toner may scatter and cause burns or other damage.



CAUTION
It is illegal to reproduce certain types of documents. Do not reproduce such documents.





⚠ CAUTION
The inside of this product has areas subject to high temperature, which may cause burns. When checking the inside of the unit for malfunctions such as a paper misfeed, do not touch the locations (around the fusing unit, etc.) which are indicated by a "Caution HOT" caution label. A burn could result.

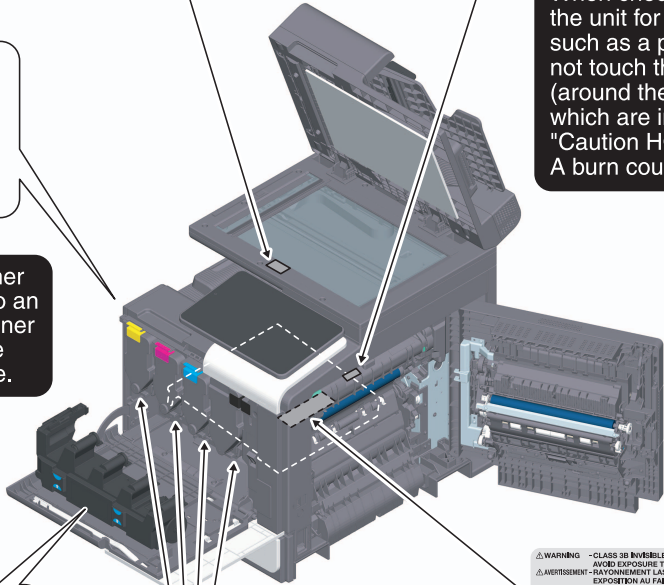

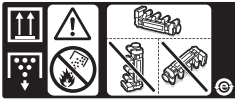
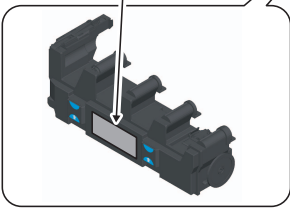
⚠ WARNING
Do not throw a container that contains toner into an open flame. The hot toner may scatter and cause burns or other damage.



⚠ CAUTION
Do not touch the electrical contacts of the units (e.g., toner cartridge and developing unit), as an electrostatic discharge may damage the product.



⚠ WARNING
Do not alter or remove any covers or panels attached to this machine. Some products have a high-voltage part or a laser beam source inside that could cause an electrical shock or blindness.

CAUTION
Do not position the used waste-toner box so that it is standing on end or tilted, otherwise toner may spill.

NOTICE
Do not remove caution labels or notations. If any caution label or caution notation is soiled, please clean to make legible. If you cannot make them legible, or if the caution label or notation is damaged, please contact your service representative.

1.6 Special notice to user

For Canada

This product meets the applicable Innovation, Science and Economic Development Canada technical specifications.

Le présent produit est conforme aux spécifications techniques applicables d'Innovation, Sciences et Développement économique Canada.

The Ringer Equivalence Number (REN) indicates the maximum number of devices allowed to be connected to a telephone interface. The termination of an interface may consist of any combination of devices subject only to the requirement that the sum of the RENs of all the devices not exceed five.

L'indice d'équivalence de la sonnerie (IES) sert à indiquer le nombre maximal de dispositifs qui peuvent être raccordés à une interface téléphonique. La terminaison d'une interface peut consister en une combinaison quelconque de dispositifs, à la seule condition que la somme des IES de tous les dispositifs n'excède pas cinq.

For U.S.A.

FCC PART 68 REQUIREMENTS:

This equipment complies with Part 68 of the FCC rules and the requirements adopted by the ACTA. On the cover of this equipment is a label that contains, among other information, a product identifier in the format US:AAEQ##TXXXX. If required, this information must be provided to the telephone company.

This equipment uses certification jack USOC RJ11C.

A plug and jack used to connect this equipment to the premises wiring and telephone network must comply with the applicable FCC Part 68 rules and requirements adopted by the ACTA.

A compliant telephone cord and modular plug is provided with this product. It is designed to be connected to a compatible modular jack that is also compliant. See installation instructions for details.

The REN is used to determine the number of devices that may be connected to a telephone line. Excessive RENs on a telephone line may result in the devices not ringing in response to an incoming call. In most but not all areas, the sum of RENs should not exceed five (5.0).

To be certain of the number of devices that may be connected to a line, as determined by the total RENs, contact the local telephone company. For products approved after July 23, 2001, the REN for this product is part of the product identifier that has the format US: AAEQ##TXXXX. The digits represented by ## are the REN without a decimal point (e.g., 03 is a REN of 0.3). For earlier products, the REN is separately shown on the label.

If this equipment FK-517 causes harm to the telephone network, the telephone company will notify you in advance that temporary discontinuance of service may be required. But if advance notice isn't practical, the telephone company will notify the customer as soon as possible. Also, you will be advised of your right to file a complaint with the FCC if you believe it is necessary.

The telephone company may make changes in its facilities, equipment, operations or procedures that could affect the operation of the equipment. If this happens the telephone company will provide advance notice in order for you to make necessary modifications to maintain uninterrupted service.

If trouble is experienced with this equipment FK-517, for repair or warranty information, please contact the Konica Minolta dealer location where you purchased this equipment. If the equipment is causing harm to the telephone network, the telephone company may request that you disconnect the equipment until the problem is resolved.

Connection to party line service is subject to state tariffs. Contact the state public utility commission, public service commission or corporation commission for information. If your home has specially wired alarm equipment connected to the telephone line, ensure the installation of FK-517 does not disable your alarm equipment. If you have questions about what will disable alarm equipment, consult your telephone company or a qualified installer.

The Telephone Consumer Protection Act of 1991 makes it unlawful for any person to use a computer or other electronic device, including FAX machines, to send any message unless such message clearly contains in a margin at the top or bottom of each transmitted page or on the first page of the transmission, the date and time it is sent and an identification of the business or other entity, or other individual sending the message and the telephone number of the sending machine or such business, other entity, or individual. (The telephone number provided may not be a 900 number or any other number for which charges exceed local or long-distance transmission charges.)

In order to program this information into your FAX machine, you should complete the following steps: See Sending after Renaming the Sender ([Sender Settings]), of the User's Guide [Fax].

WARNING/CAUTION Explained

WARNING

- The exclamation point within an equilateral triangle followed by the word "Warning" is intended to alert the user to the possibility that a disregard for the warning may result in fatal hazards or critical injuries. Be sure to focus your attention on the Warning headings when reading this Quick Guide.

CAUTION

- The exclamation point within an equilateral triangle followed by the word "Caution" is intended to alert the user to the possibility that a disregard for the caution may result in minor injuries or in physical damage. Be sure to focus your attention on the Caution headings when reading this Quick Guide.

For Europe

The Facsimile has been confirmed to meet the standards (or requirements) ETSI for pan-European single terminal connection to the public switched telephone network (PSTN).

For New Zealand

This device is equipped with pulse dialing while the Telecom standard is DTMF tone dialing. There is no guarantee that Telecom lines will always continue to support pulse dialing.

Use of pulse dialing, when this equipment is connected to the same line as other equipment, may give rise to bell tinkle or noise and may also cause a false answer condition. Should such problems occur, the user should not contact the Telecom Fault Service.

This equipment may not provide for the effective hand-over of a call to another device connected to the same line.

The grant of a Telepermit for any item of terminal equipment indicates only that Telecom has accepted that the item complies with minimum conditions for connection to its network. It indicates no endorsement of the product by Telecom, nor does it provide any sort of warranty. Above all, it provides no assurance that any item will work correctly in all respects with another item of Telepermitted equipment of a different make or model, nor does it imply that any product is compatible with all of Telecom's network services.

The automatic calling functions of this equipment must not be used to cause a nuisance to other customers.

Telepermitted equipment only may be connected to the auxiliary telephone port. The auxiliary port is not specifically designed for 3-wire connected equipment. 3-wire might not respond to incoming ringing when connected to this port.

1.7 Space requirements

To ensure that machine operation, consumables replenishing, part replacement, and regular maintenance can easily be performed, adhere to the recommended space requirements detailed below.

For North America

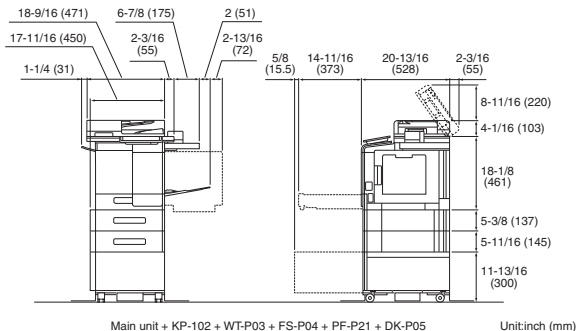

For other

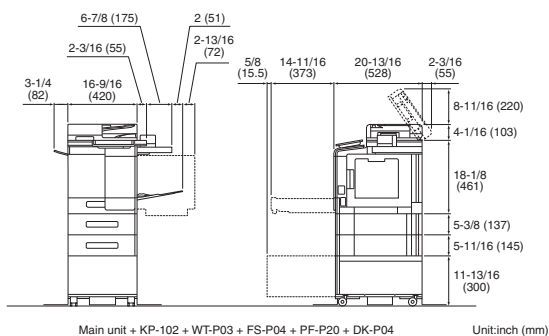

NOTICE

Be sure to allow a clearance of 8 inches (200 mm) or more at the back of this machine for the ventilation duct.

1.8 Operation precautions

To ensure the optimum performance of this machine, observe the precautions described below.

Power source

The power source requirements are as follows.

- Voltage fluctuation: Maximum $\pm 10\%$ (at 110 to 127 V/220 to 240 V AC)
- Frequency fluctuation: Maximum ± 3 Hz (at 50 Hz/60 Hz)
- Use a power source with as little voltage or frequency fluctuations as possible.

Operating environment

The environmental requirements for correct operation of the machine are as follows.

- Temperature: 50°F (10°C) to 86°F (30°C) with fluctuations of no more than 18°F (10°C) within an hour
- Humidity: 15% to 85% with fluctuations of no more than 10% within an hour

Storage of copies

To store copies, follow the recommendation listed below.

- Copies that are to be kept for a long time should be kept where they are not exposed to light in order to prevent them from fading.
- Adhesive that contains solvent (e.g., spray glue) may dissolve the toner on copies.
- Color copies have a thicker layer of toner than normal black-and-white copies. Therefore, when a color copy is folded, the toner at the fold may peel off.

Data stored in this machine

It is suggested to delete all data stored in all storage areas using the overwrite all data function to prevent leakage of data prior to transfer or disposal of the machine, or returning of the leased machine.

For details of the overwrite all data function, refer to the User's Guide. Contact your service representative before deleting data.

It is recommended to backup storage periodically as the measures for storage defect. For the detail information of storage backup, contact your service representative.

Precautions for carrying the machine

Lifting the machine in an awkward position or transporting it in a poorly balanced position could result in personal injury. When transporting the machine, use an adequate number of persons and ensure that each person can take a good position without being excessively burdened.

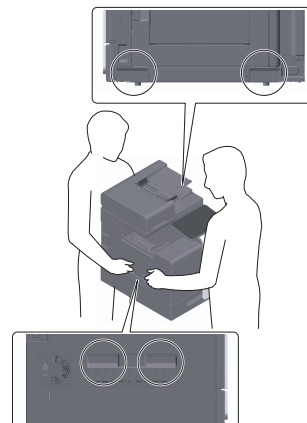

1.9 Legal restrictions on reproduction

Certain types of originals must never be reproduced with the purpose or intent to pass reproductions of such originals off as the originals.

The following is not a complete list, but is meant to be used as a guide to responsible reproduction.

<Financial Instruments>

- Personal checks
- Traveler's checks
- Money orders
- Certificates of deposit
- Bonds or other certificates of indebtedness
- Stock certificates

<Legal Originals>

- Food stamps
- Postage stamps (canceled or uncanceled)
- Checks or drafts drawn by government agencies
- Internal revenue stamps (canceled or uncanceled)
- Passports
- Immigration papers
- Motor vehicle licenses and titles
- House and property titles and deeds

<General>

- Identification cards, badges, or insignias
- Copyrighted works without permission of the copyright owner

In addition, it is prohibited under any circumstances to reproduce domestic or foreign currencies, or works of art without permission of the copyright owner.

When in doubt about the nature of an original, consult with legal counsel.

NOTICE

This machine provides the forgery prevention function in order to prevent financial instruments from being reproduced illegally.

We appreciate your understanding that printed images may infrequently have some noise or image data may not be stored under certain circumstances due to this forgery prevention function.

2 Before Using this Machine

2.1 Environmental initiatives

The company continuously strives to reduce the negative environmental impacts of all stages of its business operations.

As part of such activities, the company is implementing resource-saving steps by reducing the number of pages in the User's Guide.

For the information necessary to operate the machine, please refer to the bundled User's Guide CD (HTML format). This guide has an excellent search function.

Functions such as keyword search and filtering by purpose are very useful to help users find what they need to know.

2.2 Intended use of office MFP devices

Intended use

This Multi Function Product incorporates the functionality of multiple office devices in one. It is designed to be used as an office system for the following purposes:

- Print, copy, scan and fax documents.
- Use available finishing functions such as duplexing and stapling if appropriate options are installed.
- Store scanned documents on external USB memory devices; send scanned documents to network scan destinations such as FTP, WebDAV and E-mail.

The intended use also requires that:

- The system is used within the limits of device specifications and specifications of optional components,
- All safety instructions in the related user's guides are observed,
- Legal restrictions on reproduction (page 8) are observed,
- Inspection and maintenance instructions are adhered to,
- General, national and company safety provisions are observed.

Impermissible operating conditions

The system may not be operated if:

- Errors or damage have been discovered,
- Maintenance intervals have been exceeded,
- Mechanical or electrical functions do not work as they should.

Exclusion of liability

The manufacturer of the system assumes no liability for damages if the system was operated under impermissible conditions.

2.3 Target groups

The user's guides are intended for the following users of the system:

Target group	Description
User	Persons using the system for objectives described in "Intended use of office MFP devices" as well as managing system functions and consumables according to the assigned user rights.
Administrator	Persons managing consumables, system functions, users and access rights; adjusting system settings, and establishing network connections.

Everyone who uses this system must have read and understood the related user's guides.

2.4 Introduction to user's guide

The user's guide of this product consists of this manual and the HTML User's Guide.

This manual describes notes and precautions that should be followed in order to use this machine safely, and also provides information about basic functions and operation methods.

If you want to learn about more detailed functions or operation methods, refer to the HTML User's Guide included in the User's Guide CD.

Quick Guide

This document describes notes and precautions that should be followed in order to use this machine safely, and also provides information about basic functions and operation methods.







Be sure to read this guide before use.

HTML User's Guide

This User's Guide is included in the User's Guide CD.

The User's Guide provides basic and detailed information on the functions of this product and also explanations of other various setting functions.

2.5 Symbols and notations used in this manual

Symbol/notation	Description
 WARNING	Improper handling can cause serious injury or death.
 CAUTION	Improper handling can cause minor injury or damage to houses and property.
NOTICE	This symbol indicates a risk that may result in damage to this machine or documents. Follow the instructions to avoid property damage.
✓	This check mark symbol shows a precondition of a procedure.
→	This symbol indicates a supplementary explanation of a procedural instruction.
 Tips	This symbol indicates supplemental information of a topic as well as options required to use a function.
 Reference	This symbol indicates reference functions related to a topic.
 Related setting	This shows the settings related to a particular topic for any user.
 Related setting (for the administrator)	This shows the settings related to a topic only for administrators.
[]	An item enclosed by brackets [] indicates a key name on the Touch Panel or computer screen, or the name of a user's guide.
Bold text	This presents a part name, product name, or option name.

2.6 Administrator password

The administrator password is set to [1234567812345678] by factory default. Try this password if the administrator password has not been changed.

Change the administrator password periodically.

3 How to Use the HTML User's Guide

About the HTML User's Guide

The HTML User's Guide included in the User's Guide CD can also be obtained from the following URL. To obtain the HTML User's Guide, send the URL read from the QR code to your computer.

<https://www.btapac.konicaminolta.com/dl/>



Select a desired function on the top page (Home), and check the details of the function.

Selecting [Introduction] on the top page (Home) allows you to view detailed methods for using the HTML User's Guide.

Operating environment

Supported operating systems

- Microsoft Windows 7 (SP1)/Windows 8.1/Windows 10
Apple Mac OS 10.10/10.11/10.12/10.13/10.14

Supported Web browsers

- Windows:
Microsoft Internet Explorer 10/11 (Desktop version), Microsoft Edge, Firefox latest version, Google Chrome latest version
- Mac OS:
Safari latest version

Display resolution

- 1024 × 768 pixels or more



Tips

- We recommend that you use the latest Web browser that is compatible with your operating system to help you use this machine more conveniently and comfortably.
- Check that JavaScript in your Web browser is enabled. The HTML User's Guide uses JavaScript for the page display and search functions.

Login for iTraining

iTraining provides an online product introduction in which all important functions are explained in detail in clear video sequences. Be guided step-by-step in a simple procedure and get to know your bizhub system in an easy way.

At any time – without specified times – again and again!

<https://itraining.konicaminolta.eu/en/home.html>



4 About This Machine

4.1 Optional components

List of optional components

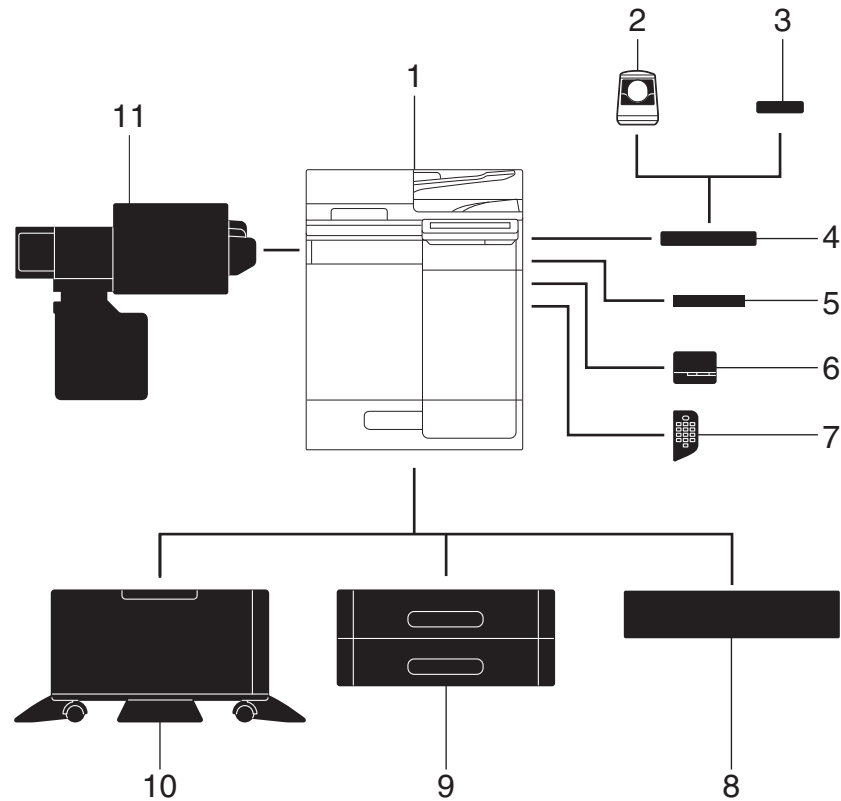

No.	Name	Description
1	Main unit	Scans the original in the scanner section, and prints a scanned image in the printer section. This unit is referred to as "this machine" or "the main unit" in the manual.
2	Authentication Unit AU-102	Performs user authentication by scanning vein patterns in the finger. The Working Table WT-P03 is required to install the Authentication Unit AU-102 .
3	Authentication Unit AU-201S	Performs user authentication by scanning information recorded on the IC card or NFC-compatible Android terminal. The Mount Kit MK-P08 is required to install the Authentication Unit AU-201S . This unit can also be installed on the Working Table WT-P03 .
4	Working Table WT-P03	Provides an area to temporarily place an original or other materials. This is also used when the Authentication Unit AU-102 or Authentication Unit AU-201S is installed. The Finisher FS-P04 can be installed as needed.
5	Keyboard Holder KH-P02	Install this holder to use an external keyboard. For details on external keyboards, contact your service representative.

No.	Name	Description
6	Finisher FS-P04	Staples the printed sheets. For staples, use Staple Kit SK-501 . For details on how to use the Finisher FS-P04 , refer to the HTML User's Guide.
7	Keypad KP-102	It is equipped on the side of the Control Panel . Allows you to operate this machine or enter a number by using hardware keys.
8	Paper Feed Unit PF-P25/PF-P22	Adjust the height of this machine to suit your conditions. Paper Feed Unit PF-P22 is only available in some areas.
9	Paper Feed Unit PF-P21/PF-P20	Paper Feed Unit PF-P21 can contain up to 500 legal-size sheets. Paper Feed Unit PF-P20 can contain up to 500 A4-size sheets. Up to two levels can be attached. Paper Feed Unit PF-P20 is only available in some areas.
10	Desk DK-P05/DK-P04	Used to install this machine on the floor. Desk DK-P04 is only available in some areas.
11	Clean Unit CU-202	Collects small particles (UFP) generated in this machine to prevent them from escaping this machine. Clean Unit CU-202 is only available in some areas.

List of other optional components

The following options are built into this machine and are not shown in the figure.

No.	Name	Description
1	Fax Kit FK-517	Used to operate this machine as a fax machine. In some areas, bizhub C4050i provides the Fax Kit as standard.
2	Local Interface Kit EK-P08	Install this unit when using the voice guidance function. The speaker and USB port are added.
3	Local Interface Kit EK-P09	Install this unit when using the voice guidance function or the connection function with a Bluetooth LE-compatible iOS terminal. The speaker, USB port, and receiving device for Bluetooth LE communication are added.
4	Local Interface Kit EK-P11	Install this unit to use the remote diagnosis system. Used to add an RS-232C port.
5	i-Option LK-102 v3	Allows you to add the PDF processing function.
6	i-Option LK-104 v3	Allows you to add the voice guidance function.
7	i-Option LK-105 v5	Allows you to add the searchable PDF function.
8	i-Option LK-106	Used to add a bar code font that is one of special fonts.
9	i-Option LK-107	Used to add a unicode font that is one of special fonts.
10	i-Option LK-108	Used to add an OCR font that is one of special fonts. In the standard, the OCR-B font (PostScript) is available. Installing this option allows a use of the OCR-A font (PCL).
11	i-Option LK-110 v3	Allows you to convert a file into the DOCX or XLSX type or generate a high functionality and the high-quality data generation function. This option includes the function licenses for i-Option LK-102 v3 and i-Option LK-105 v5 . To purchase this option, you do not need to purchase i-Option LK-102 v3 and i-Option LK-105 v5 . For details about functions able to be added, refer to the HTML User's Guide.
12	i-Option LK-111	Allows you to add the ThinPrint function.
13	i-Option LK-114	Allows you to add the serverless pull printing function.
14	i-Option LK-115 v2	Allows you to add TPM (Trusted Platform Module). Security enhancement is realized by encrypting confidential information such as certificates and passwords of this machine.
15	i-Option LK-116	Allows you to add the virus scan function.
16	i-Option LK-117	Allows you to add the IP fax (SIP) function.

No.	Name	Description
17	Upgrade Kit UK-221	Allows you to use this machine in a wireless network environment. The models for North America provide Upgrade Kit UK-221 as standard.
18	Upgrade Kit UK-P19	This unit allows you to detect that pages of the original are multiplexed on the ADF .
19	Mount Kit MK-P08	Required to have Authentication Unit AU-201S built in to the main unit.
20	Mount Kit MK-P09	Required to use Clean Unit CU-202 . Mount Kit MK-P09 is only available in some areas.

4.2 Name of each component (main unit)

Front/side

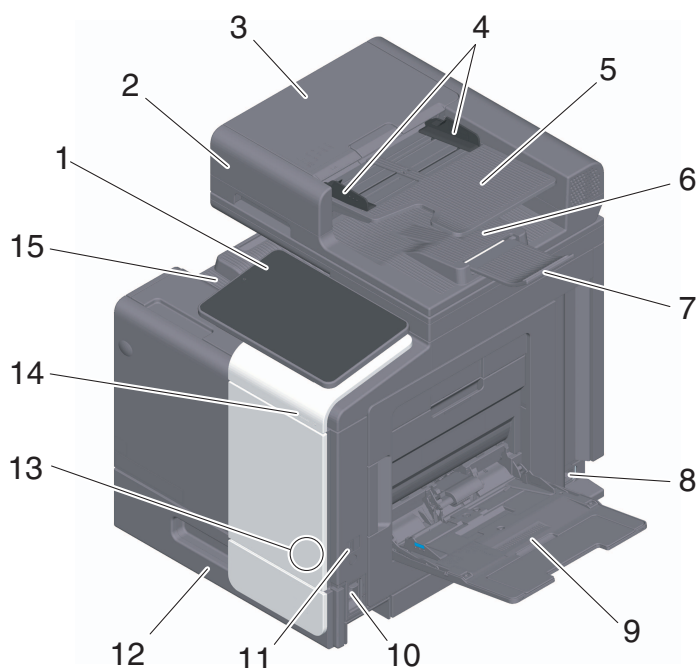

No.	Name	Description
1	Control Panel	Used to configure various settings in this machine.
2	Automatic Document Feeder	Automatically feeds and scans originals by page. This unit scans a 2-sided original by only requiring the paper be fed into the machine once without reversing. This unit is referred to as ADF in the manual.
3	ADF Feed Cover	Open this cover when clearing a paper jam in the ADF .
4	Lateral Guide	Adjust this guide along the width of the original.
5	Original Tray	Load the original face up in this tray.
6	Original Output Tray	The scanned original is fed out onto this tray.
7	Document Stopper	Used to prevent the output original from falling.
8	Power Connection	Connect the power cord to this inlet to supply power to this machine.
9	Bypass Tray	Used to print data on non-standard size paper or envelopes.
10	Main Power Switch	Press this switch to turn the machine on or off.
11	USB Port (Type A) USB2.0/1.1	Used to connect an external memory unit (USB memory unit) to this machine.

No.	Name	Description
12	Tray 1	Allows you to load up to 500 sheets.
13	Mobile Touch Area	This area is used to associate this machine with an NFC-compatible Android terminal or an iOS terminal compatible with Bluetooth LE.
14	Data Indicator	Flashes or lights up to indicate the data receiving status on this machine.
15	Output Tray	Outputs printed pages.

Rear side

This view shows the machine with the optional **Fax Kit FK-517** installed.

In some areas, **bizhub C4050i** provides the **Fax Kit FK-517** as standard.

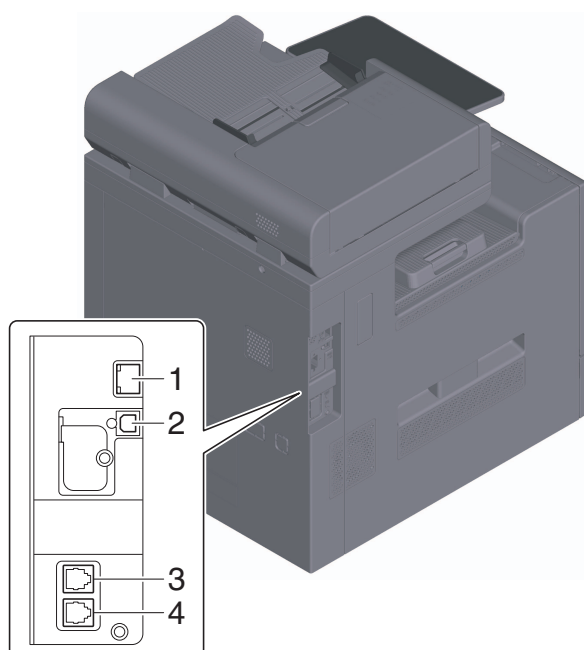

No.	Name	Description
1	Ethernet (LAN) Port (1000Base-T/100Base-TX/10Base-T)	Connect to this port when using this machine as a network printer or network scanner.
2	USB Port (Type B)	Connect to this port when using this machine as a USB-connected printer.
3	LINE (telephone line) Jack	Used to connect a general telephone subscriber line.
4	Jack for connecting a telephone (TEL)	Used to connect a telephone cord.

Tips

- The network port of this product is following No.1 and No.2. A port is activated when a network port inserts a cable.

4.3 Power supply

This machine provides the **Main Power Switch** and **Power** key.

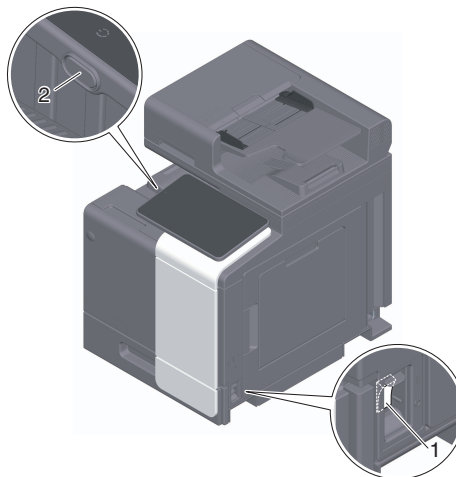

No.	Name	Description
1	Main Power Switch	Turns the main power of this machine on or off. For details on how to turn the main power on or off, refer to page 16.
2	Power key	Switches this machine to the Power Save mode. This function reduces power consumption and has a greater power saving effect. For details on how to use the Power key, refer to HTML User's Guide.

NOTICE

*While printing, do not turn the **Main Power Switch** off or press the **Power** key. Otherwise, it may lead to a paper jam.*

*If the **Main Power Switch** is turned off or the **Power** key is pressed while this machine is running, the system deletes the currently loaded data or communicating data as well as queued jobs.*

Turning the power on and off

- 1 When turning the main power on, open the **Main Power Switch Cover**, and press | of the **Main Power Switch**.

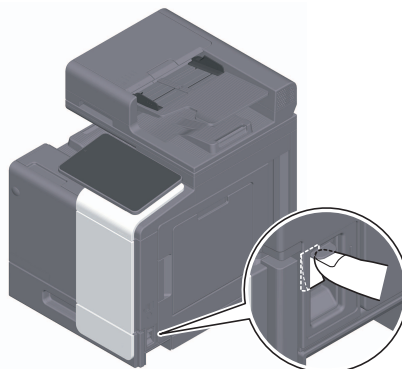

The **Power Indicator** on the **Control Panel** lights up, and the start screen is displayed on the **Touch Panel**.

- 2 When turning the main power off, open the **Main Power Switch Cover**, and press ⏻ of the **Main Power Switch**.

NOTICE

*When restarting this machine, turn the **Main Power Switch** off and on again after 10 or more seconds have passed. Not doing so may result in an operation failure.*

5 About Panels

5.1 Control Panel

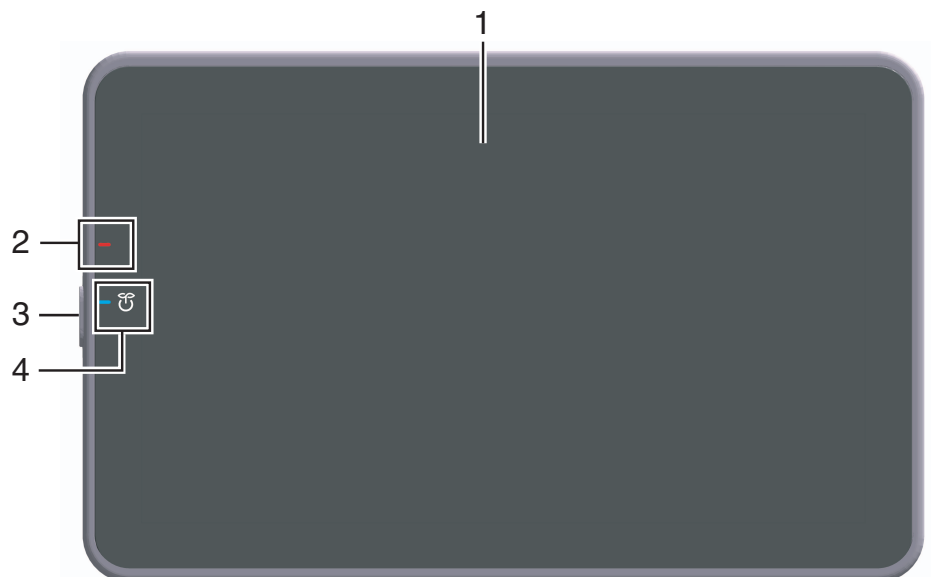

No.	Name	Description
1	Touch Panel	Displays setting screens and messages. Directly press this panel to carry out operations.
2	Warning Indicator	Indicates the status of this machine by the lamp color, flashing, or a lamp lighting up. <ul style="list-style-type: none"> • Flash (orange): Warning • Light-up (orange): The machine is stopped.
3	Power key	Switches this machine to the Power Save mode. For details on how to use the Power key, refer to HTML User's Guide.
4	Power Indicator	Indicates the power supply state by the lamp color. <ul style="list-style-type: none"> • Light-up (blue): Normal state • Flash (blue): Low Power mode or Sleep mode • Light-up (orange): Sub Power OFF • Flash (orange): ErP Auto Power OFF

5.2 Touch Panel

Home screen

The layout of the home screen is as follows.

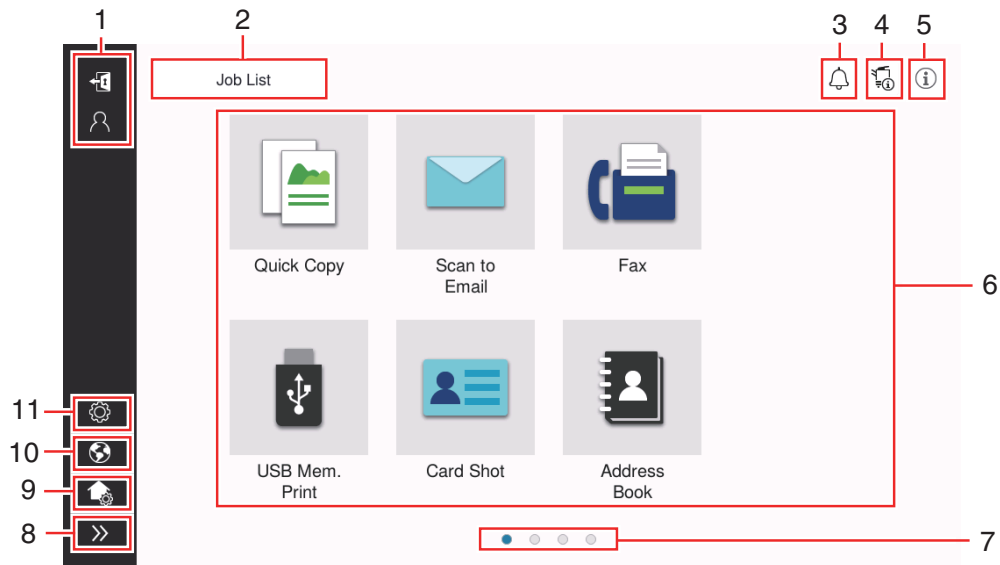

No.	Name	Description
1	User/Account Name	Displayed when user authentication and account track are enabled. Opening the left area displays the name of the current login user or the account name. Tapping [Logout] logs out.
2	[Job List]	Displays active or standby jobs. If necessary, you can check job logs or print a communication report. This list displays the operation status of the current job on the [Job List] key when it is running. If necessary, you can stop the active job using the Stop key displayed next to the [Job List] key.
3	Notification icon	You can check warnings or notices related to the status of this machine.
4	Device information icon	You can check the current date and time, free space in memory, and toner level. The corresponding device information is displayed when: <ul style="list-style-type: none"> • A nonstandard USB flash drive is connected to this machine; • Device information logs are spooled; • Image logs are transferred; • This machine is in fax redial wait state; • This machine is receiving data; • This machine is sending data; • An E-mail server (POP) connection error occurs; or • The enhanced security mode is enabled.
5	Information icon	Displays a message for users.
6	Function key	Displays shortcut keys assigned to any function.
7	Page Indicator	You can check the currently displayed page number.
8	Left area open/close icon	Opens or closes the left area. Opening the left area displays the names of the icons in the left area.
9	[Customize Home screen]	Sets the function keys to display on the home screen.
10	[Language]	Temporarily changes the language to be displayed on the panel. This option is displayed when [Temporary Change Language Setting] is set to ON.
11	[Utility]	Configure settings of this machine or check the use status of this machine.

5.3 Login methods

When user authentication is enabled:

When user authentication is enabled on this machine, the login screen is displayed. Enter the user name and the password, and perform user authentication.

- ✓ The contents of the login screen may vary depending on the authentication setting of this machine.
- ✓ If Public User Access (unregistered users) is enabled, you can tap [Used by public user] on the login screen to operate this machine without authentication.

- 1 Enter the user name and password.

- 2 When [Server Name] is displayed, select the server to perform authentication.
 - The default authentication server is selected by default.
- 3 When [Operation Rights] is displayed, select the login user's operation privileges.
 - To log in as a registered user, select [User].
 - To log in as an administrator, select [Administrator].
 - To log in as a User Box administrator, select [User Box Administrator].

- 4 When [Authentication Method] is displayed, select the authentication method.

- 5 Tap [Login].

When authentication succeeds, you can operate this machine. The user name is displayed on the screen during login.

If the login screen for account track is displayed, perform account track after this. For details on the account track operation, refer to page 20.

- 6 When the target operation is completed, select the ID key () to log out.

→ If this machine is left for a certain period of time during login (default: [1] min.), you are logged out automatically.

- 7 Tap [Yes] on the logout confirmation screen.

When account track is enabled:

When account track is enabled on this machine, the login screen is displayed. Enter the account name and the password to perform account track.

- ✓ The contents of the login screen may vary depending on the authentication setting of this machine.

1 Enter the account name and password.

- When performing account track using only the password, the keypad is displayed on the login screen. If the password is numeral alone, it is possible to enter the password using the keypad. If the password contains a character, tap the [Password] entry area, and then enter the password.

The screenshot shows a login interface with a dark top bar containing 'Login' and 'Job List' tabs, and a 'C' button. Below this are two text input fields labeled 'Account Name' and 'Password'. At the bottom of the screen, there is a row of buttons: a home icon, a back icon, a 'Reset' button, a red 'Stop' button, and a blue 'Start' button.

2 Tap [Login].

When authentication succeeds, you can operate this machine. The account name is displayed on the screen during the log in process. When user authentication and account track are enabled together, the user name is displayed on the screen.

3 When the target operation is completed, select the ID key (ID) to log out.

- If this machine is left for a certain period of time during login (default: [1] min.), you are logged out automatically.

4 Tap [Yes] on the logout confirmation screen.

6 Loading the Original and Paper

6.1 Load the original

The original loading methods are classified into two types: loading the original into the **ADF** (Automatic Document Feeder), and directly loading the original onto the **Original Glass**.

Select the appropriate one for your requirements.

6.1.1 Loading the original into the ADF

This function is useful when you want to scan an original containing multiple pages, or a sheet original of different sizes.

- Place original pages so that the first one is at the top.
- Load the original with the scanning side facing up.
- Slide the **Lateral Guide** to suit the original size.
- Pull out the **Document Stopper** (1) to prevent the scanned original from falling.

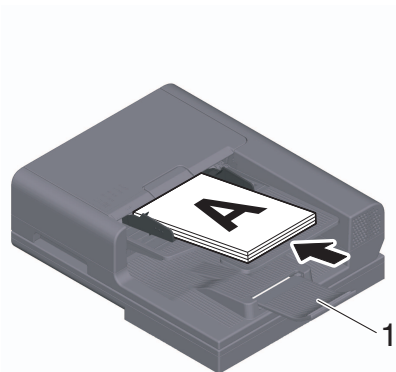

6.1.2 Placing the original on the Original Glass

This function is useful when you want to scan a small original such as a book, magazine, or business card.

- Place the original with the scanning side facing down.
- Align the original with the  mark at the left back of the **Original Glass**.

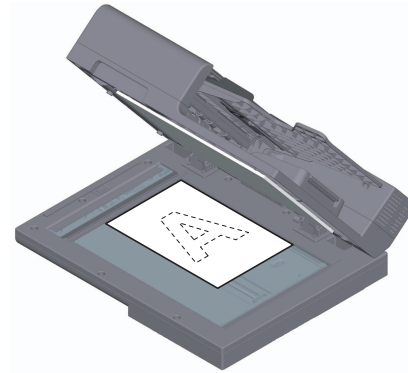

6.2 Loading paper

No paper setting is required because frequently used paper is loaded during general use.

This section describes how to use paper that is not usually loaded into a paper tray.

The methods for loading envelopes and postcards are as follows.

6.2.1 Loading paper in Tray1

Up to 500 sheets of plain paper can be loaded into **Tray 1**.

Applicable paper types

Plain paper, single-side-only paper, special paper, thick paper, postcard (4 × 6 (A6 Card)), letterhead, colored paper, envelope, label sheets, recycled paper, and coated paper

How to load paper

- 1 Pull out the tray.

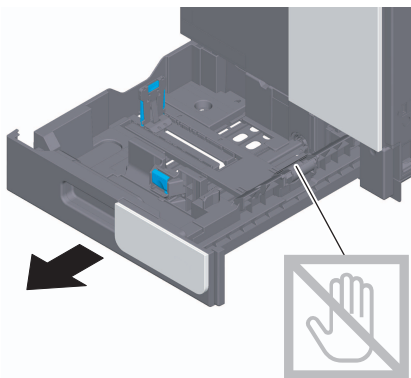

NOTICE

Be careful not to touch the surface of the **Paper Feed Rollers** with your hand.

- 2 Slide the **Lateral Guide** to fit the size of the loaded paper.

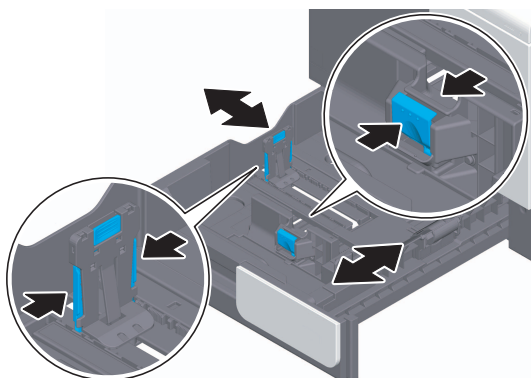

- 3 Load paper into the tray with the print side facing up.

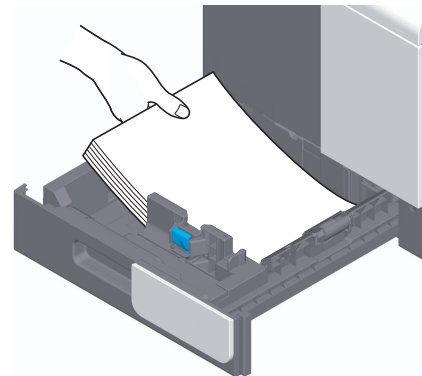

- 4 When you load paper other than plain paper or change the paper size, specify the paper type and paper size.

→ For details on how to specify the paper type and paper size, refer to the HTML User's Guide.

6.2.2 Loading paper into the Bypass Tray

When selecting a paper size other than for paper trays, use the **Bypass Tray**.

To use the **Bypass Tray**, specify the paper type and paper size.

Applicable paper types

Plain paper, single-side-only paper, special paper, thick paper, postcard (4 × 6 (A6 Card)), letterhead, colored paper, envelope, label sheets, recycled paper, and coated paper

How to load paper

- 1 Open the **Bypass Tray**.

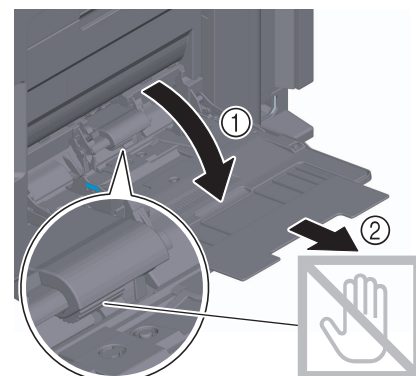

NOTICE

Be careful not to touch the surface of the **Paper Feed Rollers** with your hand.

- 2** Load paper into the tray with the print side facing down.

→ Insert paper into the tray until their edges are pressed against the back.

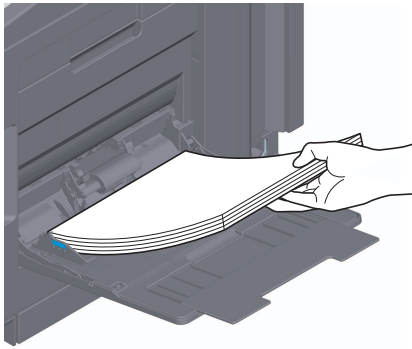

NOTICE

Do not load an excessive number of sheets such that the top of the stack is higher than the ▼ mark.

If paper is curled, flatten it before loading it.

- 3** Slide the **Lateral Guide** to fit the size of the loaded paper.

- 4** Specify the paper type and paper size.

→ For details on how to specify the paper type and paper size, refer to the HTML User's Guide.

6.2.3 Loading envelopes

Precautions when using envelopes

- Remove air from the envelope(s), and securely press along the flap fold line.
- Do not use envelopes that have glue or release paper on the flap or the part covered by the flap on the body.
- The flap side of envelopes cannot be printed on.
- When loading envelopes with flaps opened, also select the standard size that matches them. You do not have to measure the size of the envelope with the flap opened to set the size as a custom-sized envelope.

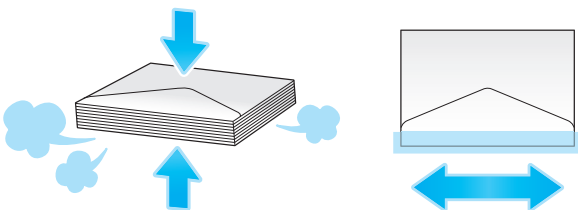

For Tray 1

Up to 30 envelopes can be loaded into the tray.

- Load envelopes with the flap part facing down.
- Align the **Lateral Guide** with the envelope size.
- Select the desired envelope size from [Envelop/4 × 6] ([Envelop/A6 Card]) of [Paper Size].

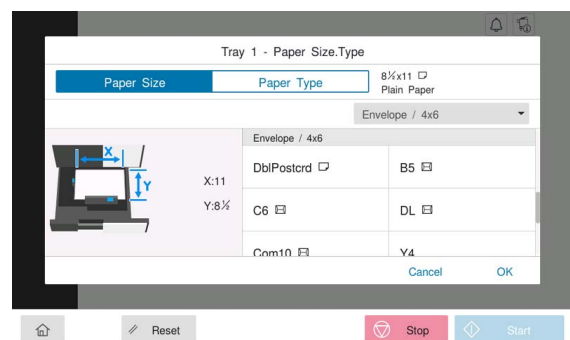
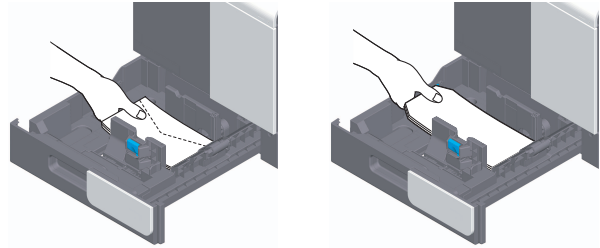

For Bypass Tray

Up to 10 envelopes can be loaded into the tray.

- Load envelopes with the flap part facing up.
- Align the **Lateral Guide** with the envelope size.
- Select the desired envelope size from [Envelop/4 × 6] ([Envelop/A6 Card]) of [Paper Size].

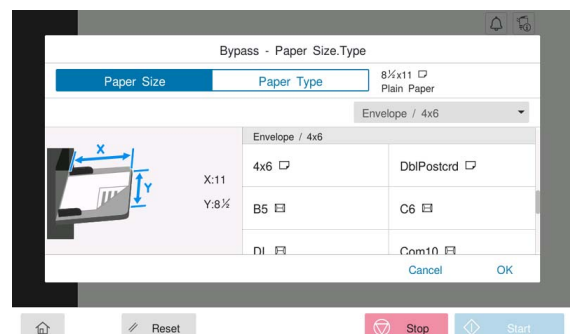
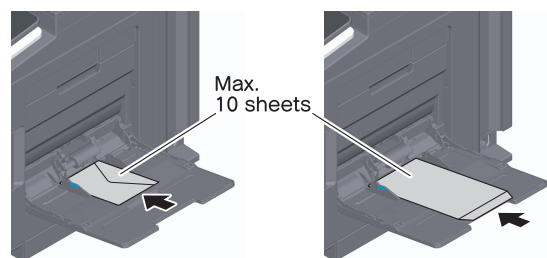

6.2.4 Loading postcards

Precautions when using postcards

- When loading curled postcards, uncurl them.
- When using postcards other than 4 × 6 (A6 Card), confirm its size, and select [Paper Size] - [Custom Size] to specify the size.

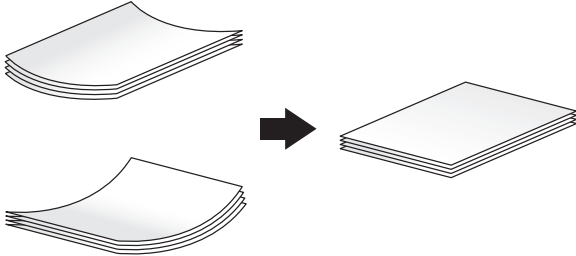

For Tray 1

Up to 20 postcards can be loaded into the tray.

- Load postcards with the print side facing up.
- Align the **Lateral Guide** with the postcard size.
- Select the desired postcard size from [Envelop/4 × 6] ([Envelop/A6 Card]) of [Paper Size].

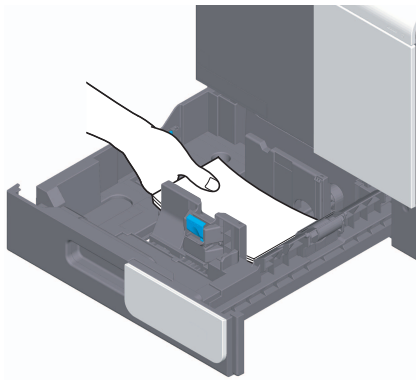

For Bypass Tray

Up to 20 postcards can be loaded into the tray.

- Load postcards with the print side facing down.
- Align the **Lateral Guide** with the postcard size.
- Select the desired postcard size from [Envelop/4 × 6] ([Envelop/A6 Card]) of [Paper Size].

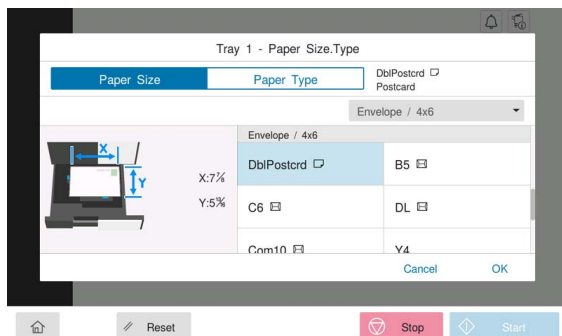
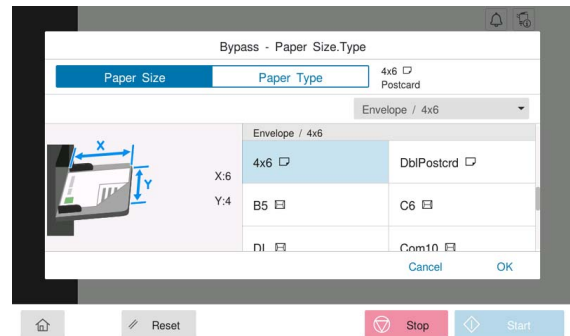
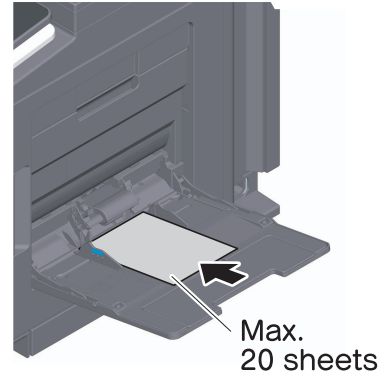

7 Available Operations in this Machine

This machine provides the copy function, print function, and scan/fax function as major functions. This section describes the basic operations for each function.

If you want to learn about more detailed descriptions or operation methods, refer to the HTML User's Guide included in the User's Guide CD.

7.1 How to copy

Basic copy operations

This section describes the basic copy operations.

- 1 If user authentication is enabled, the login screen appears. Enter the required items, and tap [Login].

- 2 Load the original.

→ When loading the original into the **ADF**, pull out the **Document Stopper** (1) to prevent the scanned original from falling.

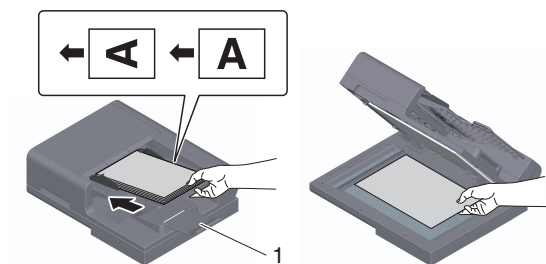

- 3 Tap [Copy] on the home screen.



- 4 Set copy options as needed.

→ Specify the size of the target original in [Scan Size] (default: [8-1/2 × 11] (inch area)/[A4] (centimeter area)). If you fail to set the original size correctly, the image may be cut off.

- 5 If necessary, specify the number of copies using the keypad.

- 6 Use the Start key to start copying.

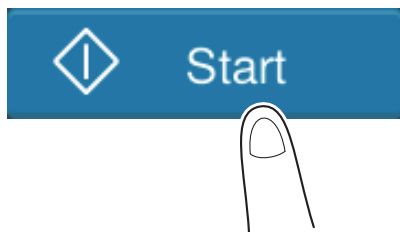

7.2 How to print

Basic print operations

This section describes the basic print operations.

- 1 Open document data using the application software. From the [File] menu, select [Print].
- 2 Check the [Printer Name] (or [Select Printer]) make sure that the desired printer has been selected.
 - The [Print] dialog box differs depending on the application.

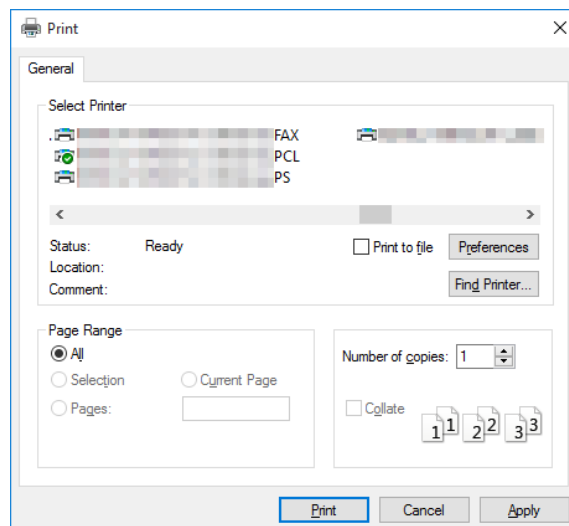

- 3 Specify the print range and the number of copies to print.
- 4 Click [Properties] (or [Preferences]) to change the print settings of the printer driver as necessary.
- 5 Click [Print].

7.3 How to scan

Basic scan operations

This section describes the basic scan operations.

- 1 If user authentication is enabled, the login screen appears. Enter the required items, and tap [Login].

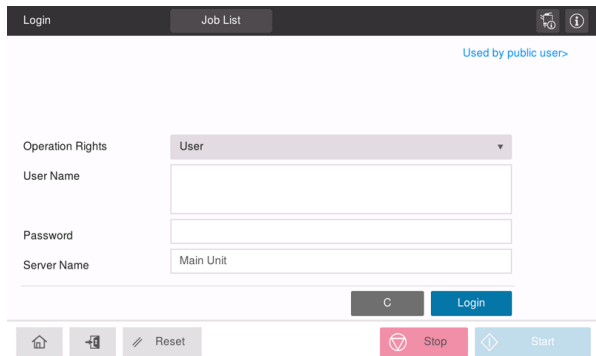

- 2 Load the original.
 - When loading the original into the **ADF**, pull out the **Document Stopper** (1) to prevent the scanned original from falling.

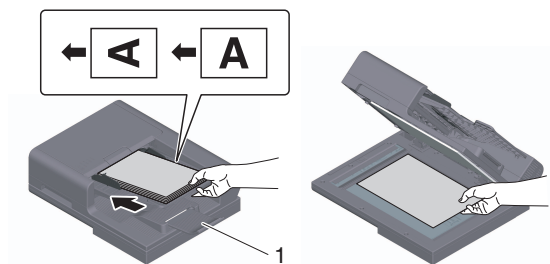

- 3 Tap the scan function key on the home screen.
- 4 Specify the destination.

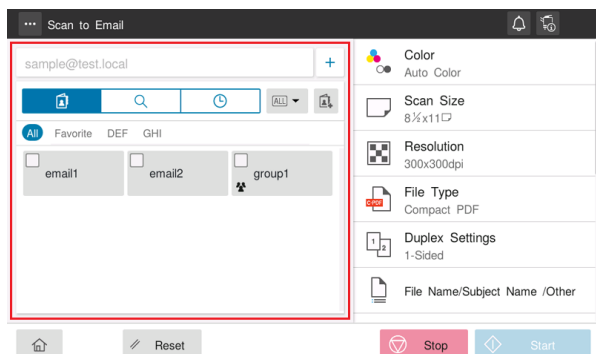

- 5 Specify transmission options as needed.
 - Specify the size of the target original in [Scan Size] (default: [8-1/2 × 11] (inch area)/[A4] (centimeter area)). If you fail to set the original size correctly, the image may be cut off.

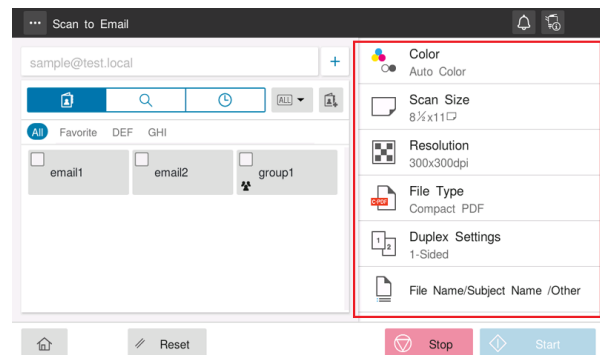

- 6 Use the Start key to start transmission.

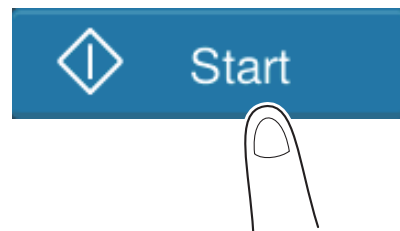

7.4 How to fax

Basic fax operations

This section describes the basic fax operations.

- 1 If user authentication is enabled, the login screen appears. Enter the required items, and tap [Login].

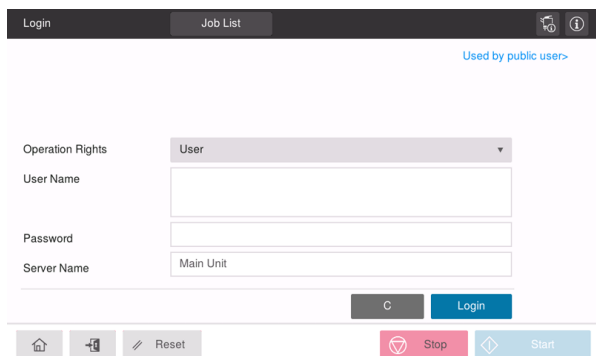

- 2 Load the original.

→ When loading the original into the **ADF**, pull out the **Document Stopper** (1) to prevent the scanned original from falling.

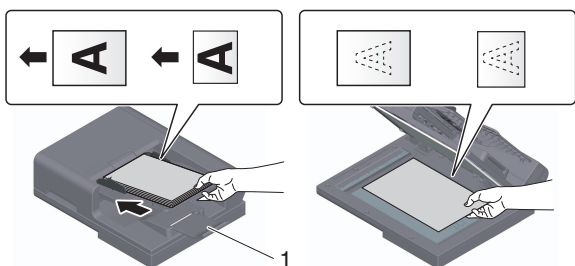

- 3 Tap [Fax] on the home screen.

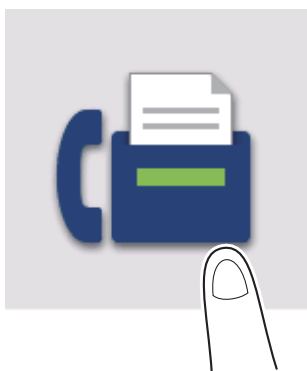

- 4 Specify the destination.

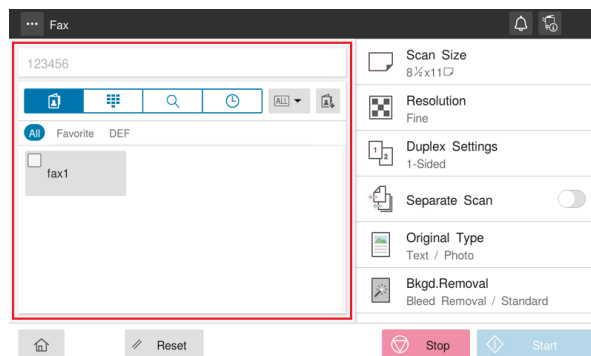

- 5 Specify transmission options as needed.

→ Specify the size of the target original in [Scan Size] (default: [8-1/2 × 11] (inch area)/[A4] (centimeter area)). If you fail to set the original size correctly, the image may be cut off.

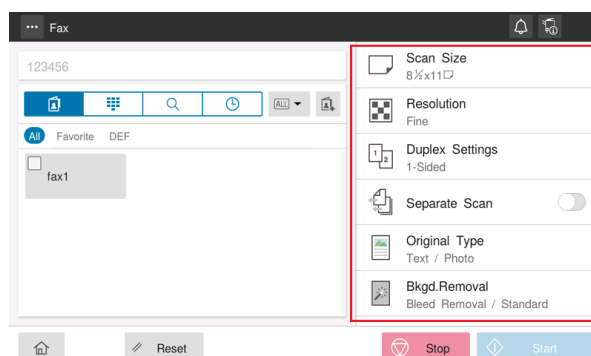

- 6 Use the Start key to start transmission.

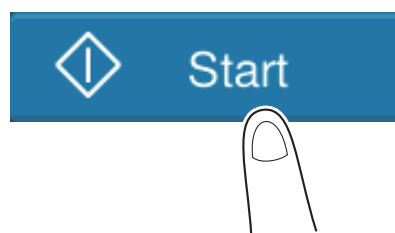

8 Registering a Destination

8.1 How to register a destination

Registering a fax address

- 1 Tap [Utility] - [Utility] - [Store Address] - [Address Book] - [New Registration].
- 2 In [Select Destination], select [Fax].
- 3 Enter destination information.

Setting	Description
[No.]	Destination registration number. Select [Use opening number] to automatically assign the smallest available number. When you want to specify a number, select [Direct Input] and then enter a number.
[Name]	Enter the destination name (using up to 24 characters).
[Index]	Select an index to search for a destination using the registered name. For a frequently used destination, select the [Main] check box. The destinations are displayed on the destination selection screen, enabling the user to easily select a destination.
[Destination]	Enter the destination fax number (using up to 38 digits, including symbols #, *, -, and characters T, P, and E). <ul style="list-style-type: none"> • [T] or [*]: Enter the fax number when issuing a push signal in dial-up line mode (while [Dialing Method] is set to [10pps] or [20pps]). • [P]: Enter this when you want to insert a wait time between dials. • [-]: Enter this to separate a dial number. It does not affect the dialing of the number. • [E-]: Enter the registered outside line number in PBX environment. This option is displayed when [PBX Connection Setting] is set to ON.
[Confirm Fax Number]	Enter the fax number again. This option is displayed when [Function ON/OFF Setting] - [Confirm Address (Register)] is set to ON.
[Communication Setting]	If necessary, specify how to send a fax to a destination you want to register. You may change the settings you made here before sending a fax. <ul style="list-style-type: none"> • [V34 Off]: V.34 is a communication mode used for super G3 fax communication. When the remote machine or this machine is connected to a telephone line via PBX, however, you may not establish a communication in the super G3 mode depending on telephone line conditions. In this case, it is recommended that you turn the V.34 mode off to send data. • [ECM Off]: ECM is an error correction mode defined by ITU-T (International Telecommunication Union - Telecommunication Standardization Sector). Fax machines equipped with the ECM feature communicate with each other, confirming that the sent data is free of errors. This prevents image blurring caused by telephone line noise. The communication time can be reduced by setting ECM to OFF for transmission. However, an image error or communication error may occur depending on the specified communication time value, so change the value to suit conditions. • [International Communication]: Used to send a fax to areas where communication conditions are poor. Faxes are sent at a lower speed. • [Check Destination]: The fax number specified for fax is checked against the destination fax number (CSI) and the fax is sent only when they match.

- 4 Tap [OK].

Registering E-mail address

- 1 Tap [Utility] - [Utility] - [Store Address] - [Address Book] - [New Registration].
- 2 In [Select Destination], select [E-mail Address].
- 3 Enter destination information.

Setting	Description
[No.]	Destination registration number. Select [Use opening number] to automatically assign the smallest available number. When you want to specify a number, select [Direct Input] and then enter a number.
[Name]	Enter the destination name (using up to 24 characters).
[Index]	Select an index to search for a destination using the registered name. For a frequently used destination, select the [Main] check box. The destinations are displayed on the destination selection screen, enabling the user to easily select a destination.
[E-mail]	Enter the E-mail address of the destination (using up to 320 characters, excluding spaces).

- 4 Tap [OK].

9 Read this if You Have a Problem

9.1 Main messages and remedies

9.1.1 Checking a notification message on the Touch Panel

The notification icon is displayed on the home screen when there is a machine condition warning or notice notification. You can tap the icon to check the notification contents.

- 1 Tap the notification icon on the home screen.

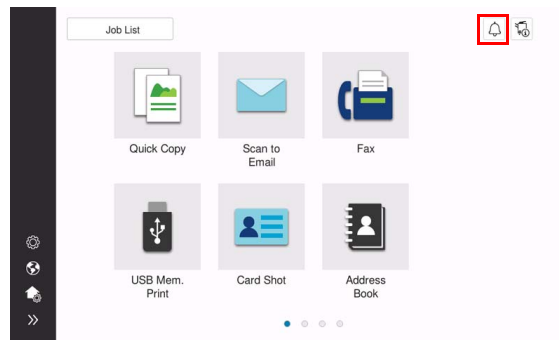

- 2 Tap [ATTENTION List], and check the notification list.

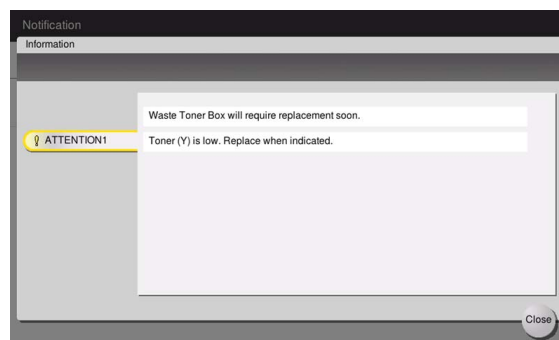

9.1.2 Screen displayed at occurrence of paper jam

If any paper jam occurs on this machine, the paper jam clearing procedure and the paper jam location are displayed on the screen of this machine. Confirm the clear procedure and jam location, and follow the guidance to clear the jam.

If a paper jam is not cleared securely, the warning message is not reset. For details on how to take an action when a paper jam message is not reset, refer to the HTML User's Guide.

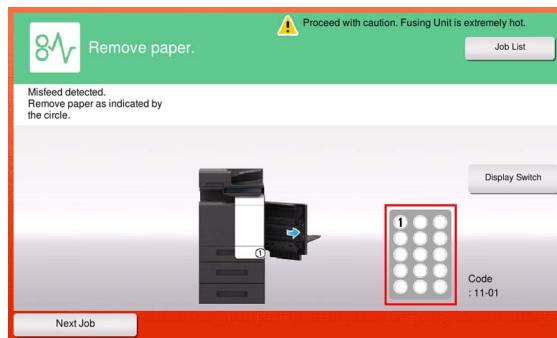
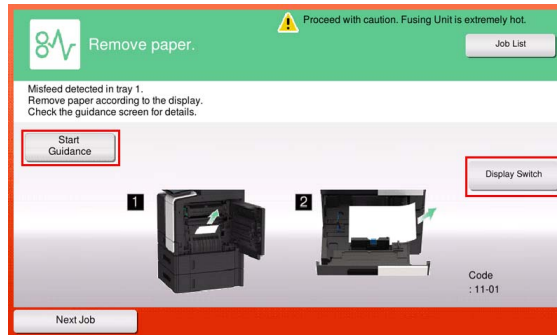

When a paper jam is cleared, a screen showing how to correctly load paper or the original is displayed.

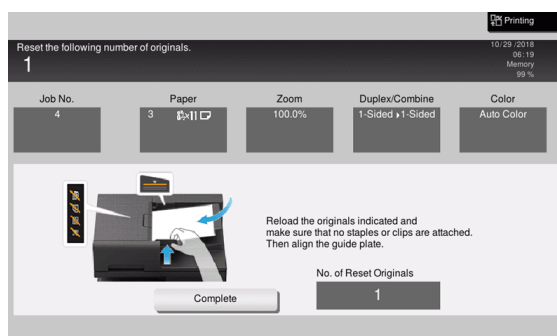
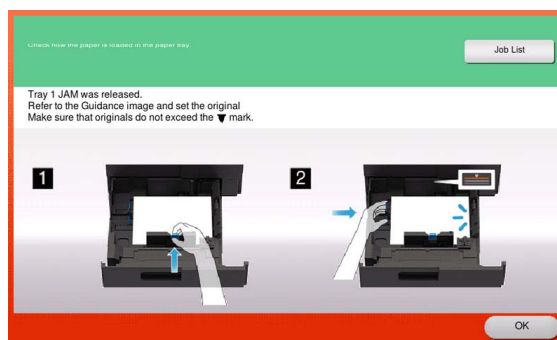

Return the original or paper, and tap [OK] or [Complete]; the system restarts scanning or printing of the original.

Item	Description
[Start Guidance]	Tap this button to start the guidance showing how to clear a paper jam.
[Display Switch]	Changes the screen that shows the paper jam clearing procedure and the screen that shows where the paper jam occurred.
Number (Indicates the paper jam position number)	Displays a list of paper jam position numbers.

9.1.3 When an error message appears

When an error is detected, the following message appears. Take the appropriate action according to the message displayed on the screen. If you cannot resolve the error, write down the [Trouble Code], and contact your service representative with the power plug disconnected from the power outlet.

In normal circumstances, the phone number and fax number for your service representative appear in the center of the screen.

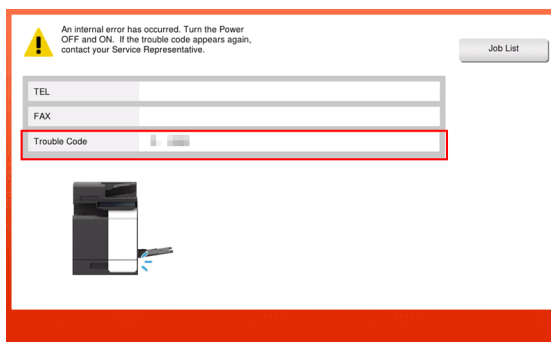

NOTICE

If a defective part can be separated in order to be able to continue operations after a problem has been detected, [Continue] or [Recover Data] is displayed. To continue operations, select any key. However, the problem has not been resolved, so contact your service representative immediately.

9.2 When the Touch Panel is not visible

If a certain length of time has elapsed without any operations being carried out on this machine, the **Touch Panel** may turn off.

Check the following items:

- Touch the **Touch Panel**. In Power Save (Low Power/Sleep) mode, this machine returns from Power Save mode when the **Touch Panel** is touched or a key on the **Control Panel** is pressed, and the **Touch Panel** appears normally.

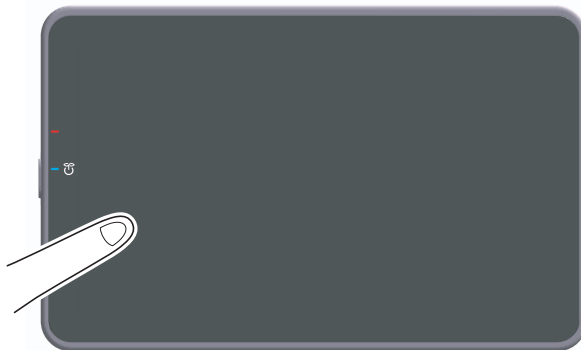

- On the **Control Panel**, press the **Power** key. If the Weekly Timer setting has put the machine in Erp Auto Power off mode, press the **Power** key to display the **Touch Panel**. To use it outside the preset operating hours, follow the on-screen instructions.

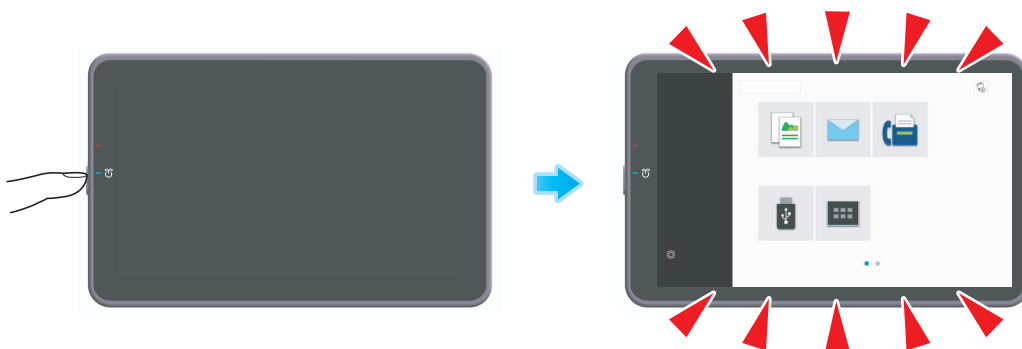

- Check to see that the **Main Power Switch** is turned ON.

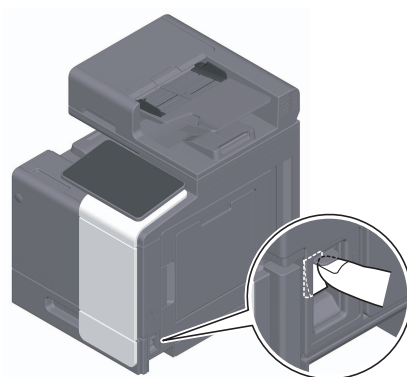

9.3 When printing quality has deteriorated

Cleaning the Original Glass and roller

Wipe the surface using a soft, dry cloth.

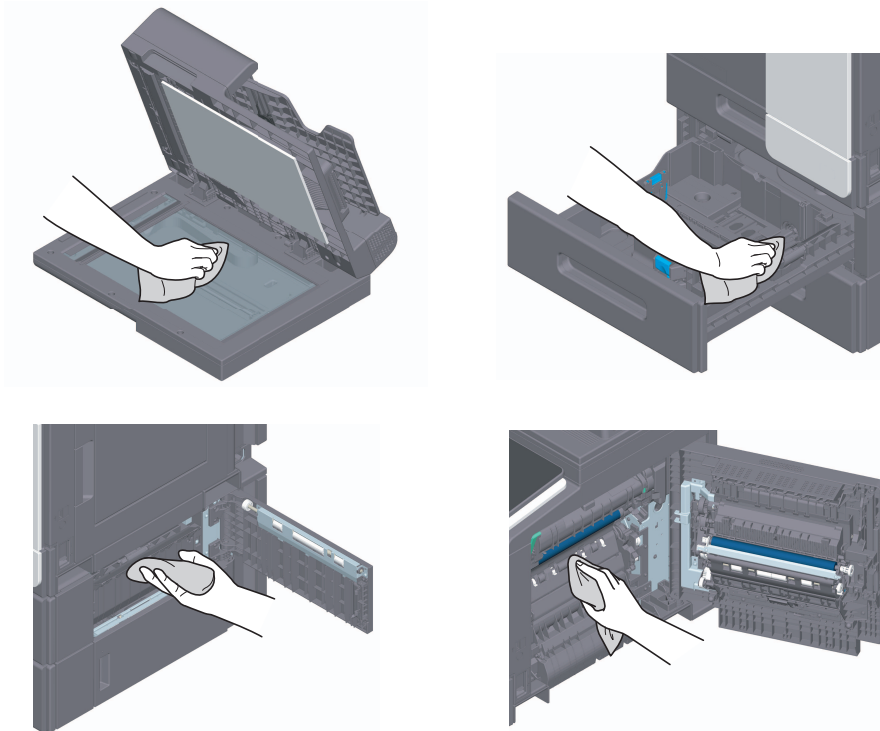

⚠ CAUTION

- The inside of this product has areas subject to high temperature, which may cause burns. When checking the inside of the unit for malfunctions such as a paper misfeed, do not touch the locations (around the fusing unit, etc.) which are indicated by a "Caution HOT" caution label. A burn could result.

Cleaning the Slit Scan Glass

Wipe stains off the glass surface using a dry, clean cloth.

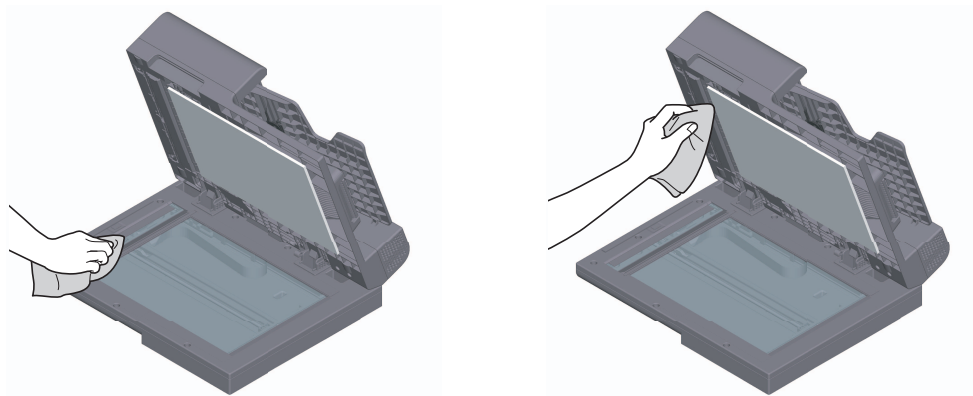

NOTICE

Do not touch the **Slit Scan Glass**.

Cleaning the Slit Scan Glass (back)

- 1 Open the **ADF**.

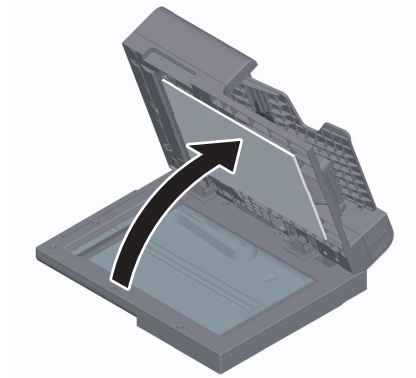

- 2 Open the **Opening and Closing Guide**.

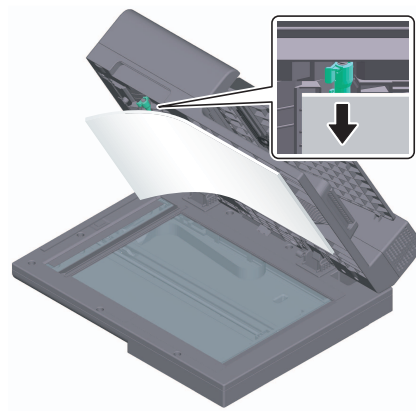

→ Release the lock lever of the **Opening and Closing Guide**, and open the **Opening and Closing Guide**.

- 3 Wipe stains off the **Slit Scan Glass (back)** and **Lateral Guide** using a dry, clean cloth.

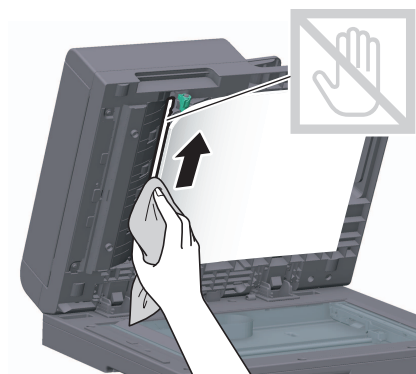

NOTICE
Do not touch the **Slit Scan Glass (back)**.

- 4** Close the **Opening and Closing Guide** you opened in step 2.

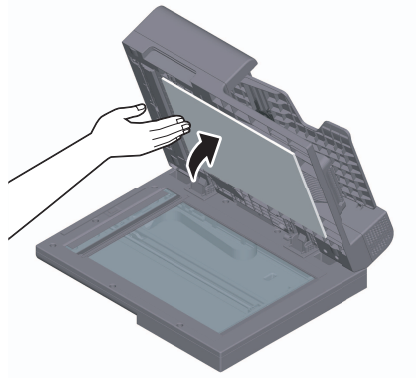

Cleaning the Print Head Glass

Printing quality deteriorates if the **Print Head Glass** is dirty. If this occurs, clean the **Print Head Glass** according to the following procedure.

- 1** Open the **Front Door** of the machine.

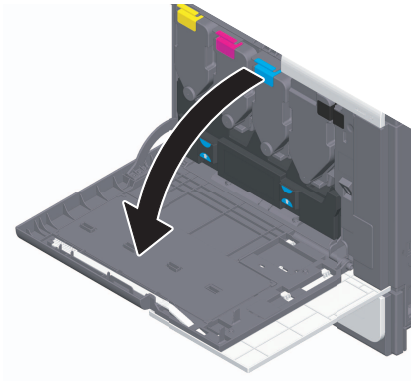

- 2** Remove the **Waste Toner Bottle**.

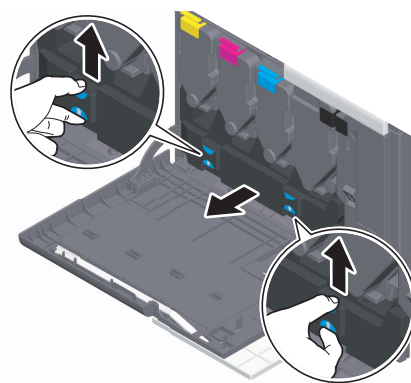

- 3** Remove the **Printhead Cleaner** from the **Front Door** of this machine.

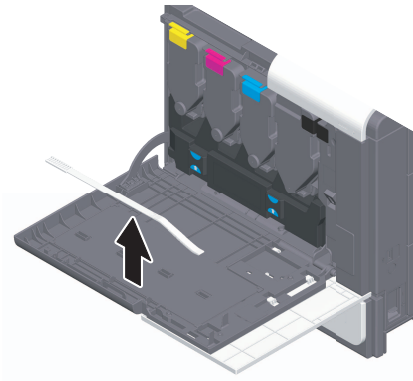

- 4** Slowly insert the **Printhead Cleaner** all the way to the back end of the **Print Head Glass**, and then slowly pull it out.
- Repeat this operation approximately three times for all the **Print Head Glass** sections.

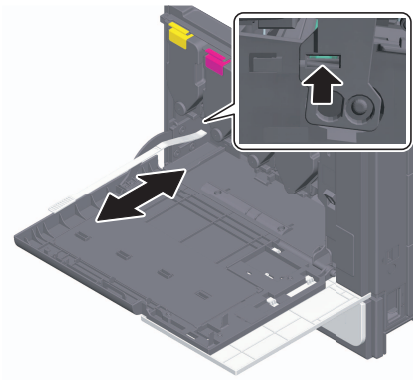

- 5** Mount the **Printhead Cleaner** onto the **Front Door** of this machine.
- 6** Mount the **Waste Toner Bottle**.
- 7** Close the **Front Door** of the machine.

9.4 When a message appears to replace consumables or carry out cleaning

A message appears indicating the time(s) that expiring consumables used in this machine should be replaced. Also, a message appears when the **Slit Scan Glass** is dirty.

Replace consumables or clean the **Slit Scan Glass** as instructed in the displayed message. Contact your service representative if the messages continue to appear even after replacement or cleaning has been carried out.

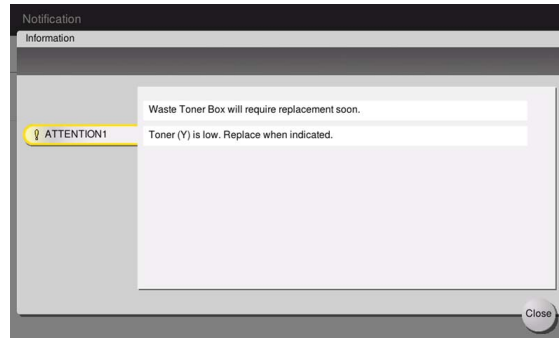

9.4.1 About Imaging Unit

When it is time to replace an **Imaging Unit**, a message appears to prompt you to contact your service representative. If the message appears, contact your service representative.

Tips

- The settings by the service representative are required to display a message about **Imaging Unit**. By the factory default status, this message is displayed only in some area. For details, contact your service representative.

9.4.2 About Toner Cartridge

When toner is running out in the Toner Cartridge

When it is almost time to replace a **Toner Cartridge**, an advanced warning message appears. Prepare a **Toner Cartridge** for replacement based on the maintenance contract.

When it is time to replace a Toner Cartridge

When it is time to replace a **Toner Cartridge**, a replacement prompt message appears. Replace it based on the maintenance contract. You can display the replacement procedure on the screen and check it.

Tips

- Do not replace a **Toner Cartridge** of a color that is not displayed.

Replacing a Toner Cartridge

The following example shows how to replace a **Yellow Toner Cartridge**.

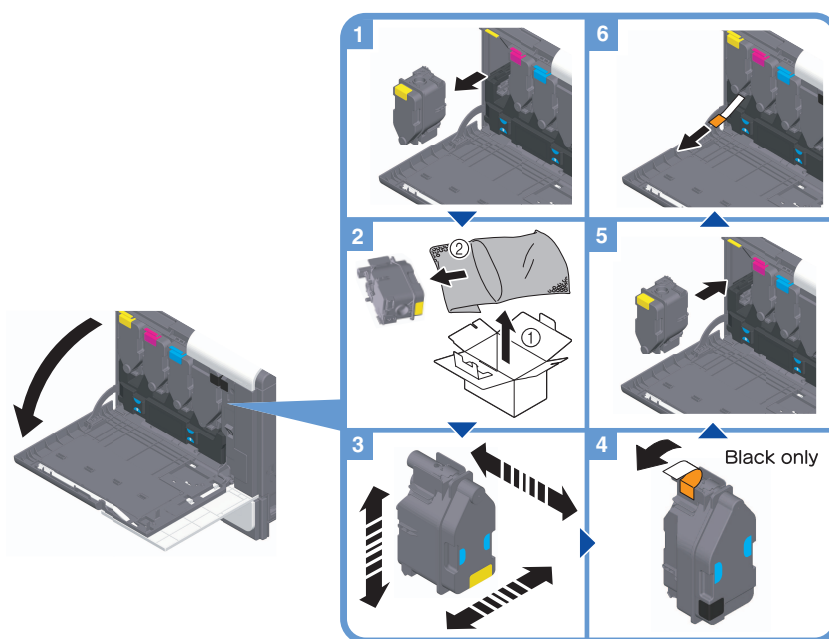

Tips

- Shake a new **Toner Cartridge** well vertically, horizontally, and back and forth, approximately 5 to 10 times, before installing it.
- If a toner cartridge other than for black is empty, printing can be continued forcibly using black. Tap [Continue], and then select a desired print job.
- Do not forcibly open or disassemble a **Toner Cartridge** (toner container).
- Do not forcibly remove or dispose of toner that remains in a **Toner Cartridge** (toner container).

NOTICE

Install a **Toner Cartridge** for each label color. If you try to forcibly install a Toner Cartridge in the incorrect position, it may result in a failure.

⚠ WARNING

- Do not throw toner or a container that contains toner (e.g., toner cartridge, developing unit and Waste Toner Box) into an open flame. The hot toner may scatter and cause burns or other damage.

⚠ CAUTION

- Never touch the electrical contacts of the units (e.g., toner cartridge and developing unit), as an electrostatic discharge may damage the product.
- Do not leave toner-related parts (e.g., toner cartridge, developing unit and Waste Toner Box) within easy reach of children. Licking any of these parts or ingesting toner could damage your health.
- Do not store toner-related parts (e.g., toner cartridge, developing unit and Waste Toner Box) near devices susceptible to magnetism, such as precision equipment and data storage devices, otherwise they may malfunction. They could cause these products to malfunction.
- Do not force open the toner-related parts (e.g., toner cartridge, developing unit and Waste Toner Box). If toner tumbles from the toner bottle, take utmost care to avoid inhaling it or even getting skin contact.
- If toner lands on your skin or clothing, wash thoroughly with soap and water.
- If you inhale toner, move to a place with fresh air and gargle with a lot of water repeatedly. Should you get symptoms such as coughing, seek medical advice.
- If you get toner into your eyes, immediately rinse them with running water for over 15 minutes. Seek medical advice if irritation persists.
- If you swallow toner, rinse out your mouth and drink a few glasses of water. Seek medical advice if necessary.

9.4.3 About Waste Toner Bottle

When the **Waste Toner Bottle** is full, a message appears to prompt you to replace it (at replacement by user). Follow the displayed guidance to take an action.

Replacing a Waste Toner Bottle

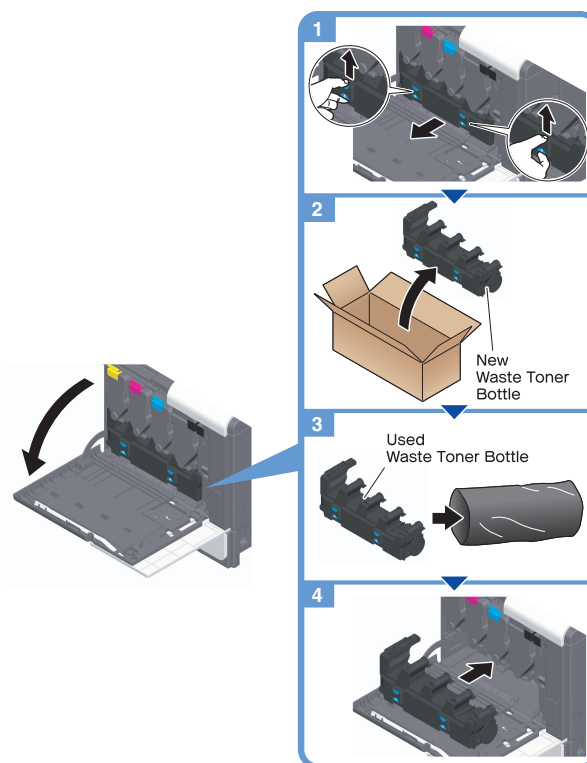

Tips

- Your service representative will collect your used **Waste Toner Bottle**. Put it in a plastic bag, and store it in a box by itself.

⚠ WARNING

- Do not throw toner or a container that contains toner (e.g., toner cartridge, developing unit and Waste Toner Box) into an open flame. The hot toner may scatter and cause burns or other damage.

⚠ CAUTION

- Do not leave toner-related parts (e.g., toner cartridge, developing unit and Waste Toner Box) within easy reach of children. Licking any of these parts or ingesting toner could damage your health.
- Do not store toner-related parts (e.g., toner cartridge, developing unit and Waste Toner Box) near devices susceptible to magnetism, such as precision equipment and data storage devices, otherwise they may malfunction. They could cause these products to malfunction.
- Do not force open the toner-related parts (e.g., toner cartridge, developing unit and Waste Toner Box). If toner tumbles from the toner bottle, take utmost care to avoid inhaling it or even getting skin contact.
- If toner lands on your skin or clothing, wash thoroughly with soap and water.
- If you inhale toner, move to a place with fresh air and gargle with a lot of water repeatedly. Should you get symptoms such as coughing, seek medical advice.
- If you get toner into your eyes, immediately rinse them with running water for over 15 minutes. Seek medical advice if irritation persists.
- If you swallow toner, rinse out your mouth and drink a few glasses of water. Seek medical advice if necessary.

9.5 Replacing a Staple Cartridge

- 1 Turn the **Finisher FS-P04** by 90 degrees.

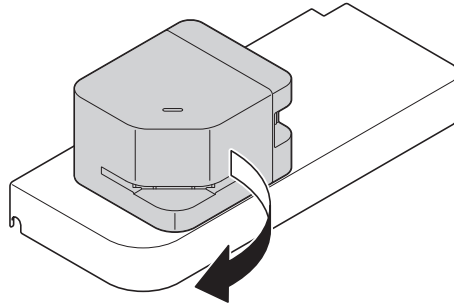

- 2 Open the cover.

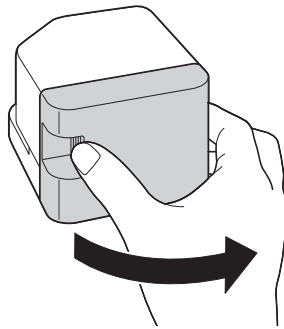

- 3 Pull out the **Staple Cartridge**.

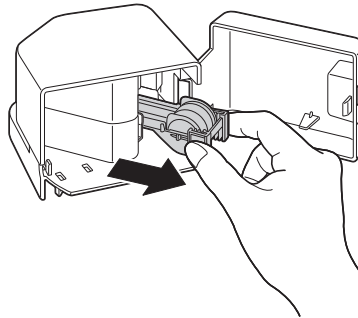

- 4 Lift an empty **Staple Case** while holding its both edges, then pull out it from the **Staple Cartridge**.

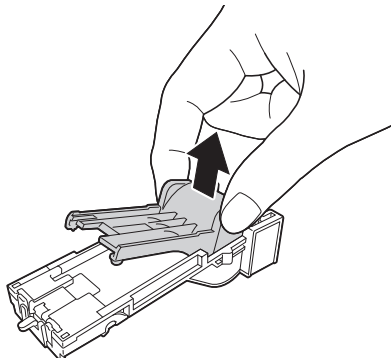

- 5** Mount a new **Staple Case** in the **Staple Cartridge**.

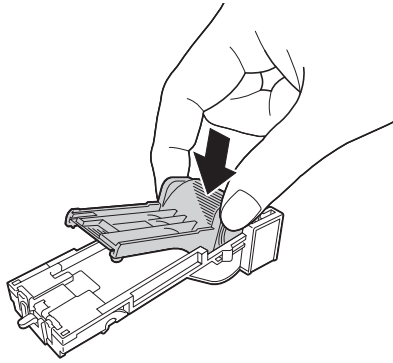

- 6** Insert the **Staple Cartridge** until it clicks.

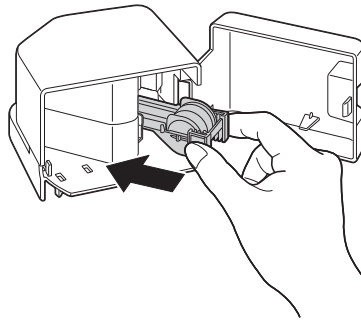

- 7** Close the cover.

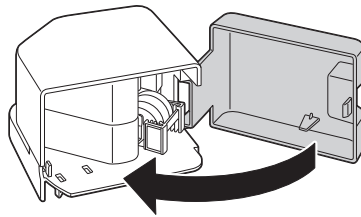

- 8** Turn the **Finisher FS-P04** by 90 degrees to return it to the home position.

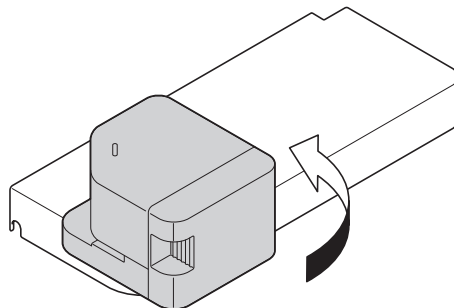



KONICA MINOLTA

<http://konicaminolta.com>



A93E-9569-22

© 2018 KONICA MINOLTA, INC.

Printed in China

2019. 9